

Miniature Rectangular Connectors



- HyperSpring® spring loaded contacts, self cleaning wiping action
- 12, 21 ways
- Combine robust environmental performance with compact size and light weight
- Easy and fast push-pull locking mechanism
- Full line EMI shielding
- IP67 sealing when mated and unmated
- D-shape hardware coding to avoid mismatching
- Overmolding solutions
- Upgrade commercial high speed Fast Ethernet, USB, IEEE 1394 interconnect to Mil Spec performances
- High-reliability commercial and military interconnect applications: Tactical Computers, Field Radios, Dismounted Soldier, Weapon Interconnect, Battery Chargers, Missiles, Helmet Breakaway System, Commercial Airframe Sensors, Autosport Diagnostics

Technical Characteristics

General		Vibration	MIL-STD-1344 method 2004 condition III
Hyperspring Contact Number	12, 21	Shock	MIL-STD-1344 method 2004
Receptacle Contact Termination	Solder Cup, Straight PCB	Weight	22 g (12) 29 g (21)
Plug Contact Termination	Solder Cup	(Plug+Receptacle- with contacts - without cabling)	
Cable Diameter Range	Max 8 mm	Materials and Plating	
AWG Contact	30 - 26	Housing	
Connector Mating Cycles	2000	- Material	Aluminium Alloy
Hyperspring Contact Force	Max 180g	- Plating	ZnCo conductive RoHS compliant
Connector Mating Force	180 g x contact number	Overmolding (Plug)	Santoprene
Connector Unmating Force	2,5 Kg	Contact	
Electrical and mechanical characteristics		- Material	Brass, CuBe
EMI Shielding	Yes	- Plating	Gold
Current Rating	3A@25°C	Environmental Characteristics	
Test Voltage (dc) Contact to Contact	300 V	Temperature Range	-65°C +80°C
Dielectric Withstanding Voltage (between contacts)	400 V	Salt Spray	MIL-STD-1344 method 1001 test condition A
Contact Resistance (low level)	< 15 mOhm	Humidity	MIL-STD-1344 method 1002 type II
Insulation Resistance	5000 MOhm @ 500V d.c. (MIL-STD1344 method 3003)	IP Level	67 mated and unmated

Dimensions are in mm

12 Ways plug connector ref. 22810

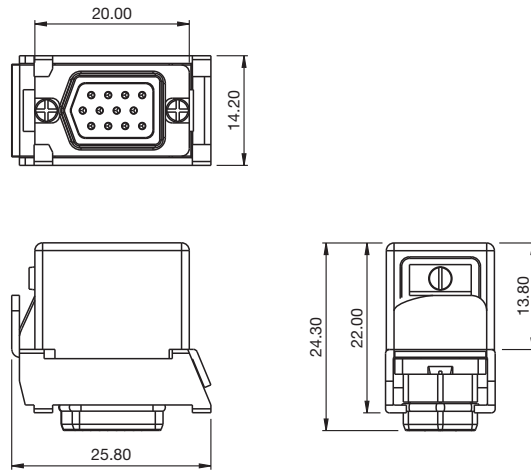

12 Ways receptacle connector solder cup termination ref. 22809

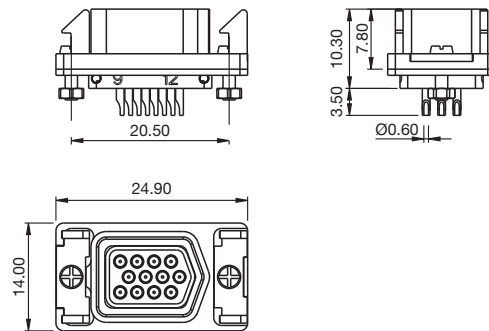

12 Ways receptacle connector straight termination ref. 22946

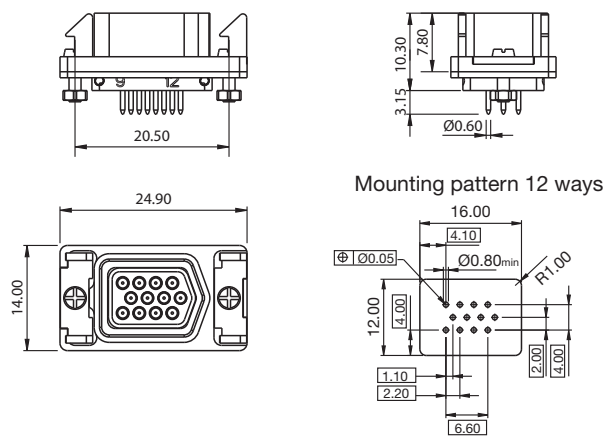

Dimensions are in mm

21 Ways plug connector ref. 22877

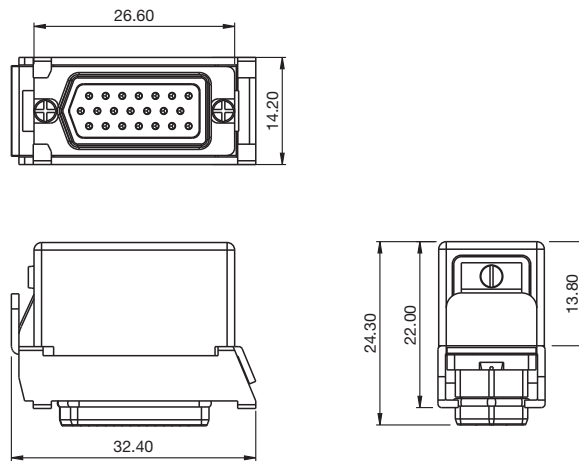

21 Ways receptacle connector solder cup termination ref. 22876

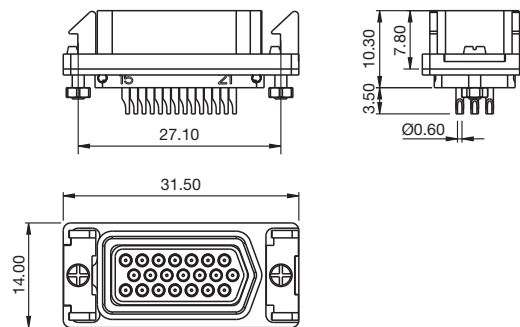

21 Ways receptacle connector straight termination ref. 22947

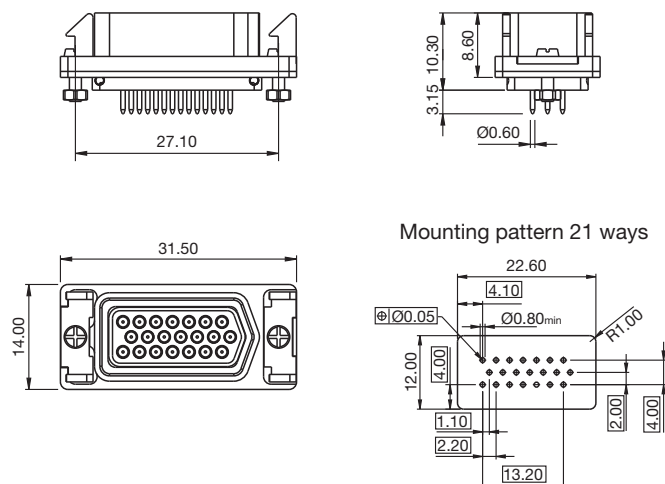

12 & 21 Ways receptacle panel cut out

12 Ways

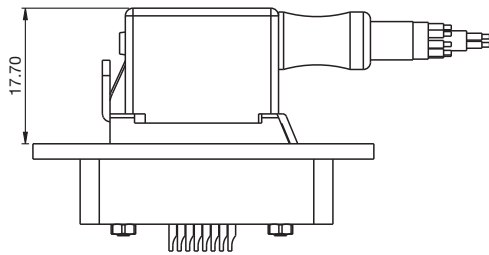
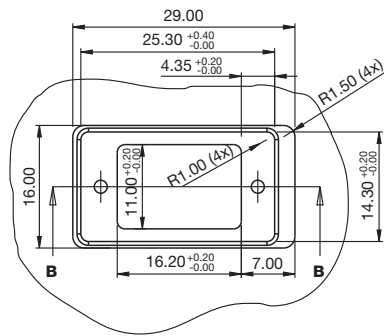
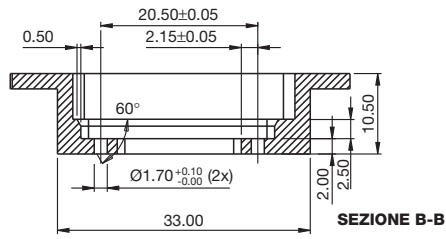

21 Ways

