

ODU MINI-SNAP



Series L - IP 50 (and IP 68)
LP-Locking Concept
Keying with Pin and Groove





The Push-Pull Locking Principle: LP

with Jaws like LEMO® (see page 9)

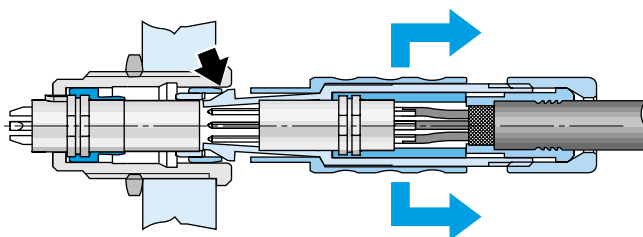
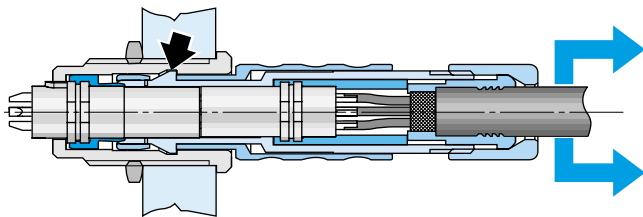
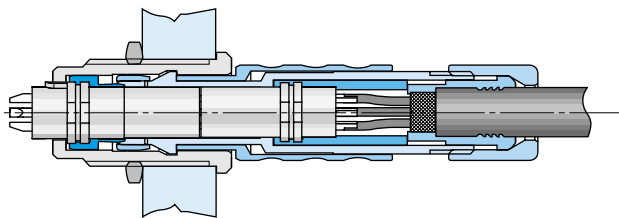
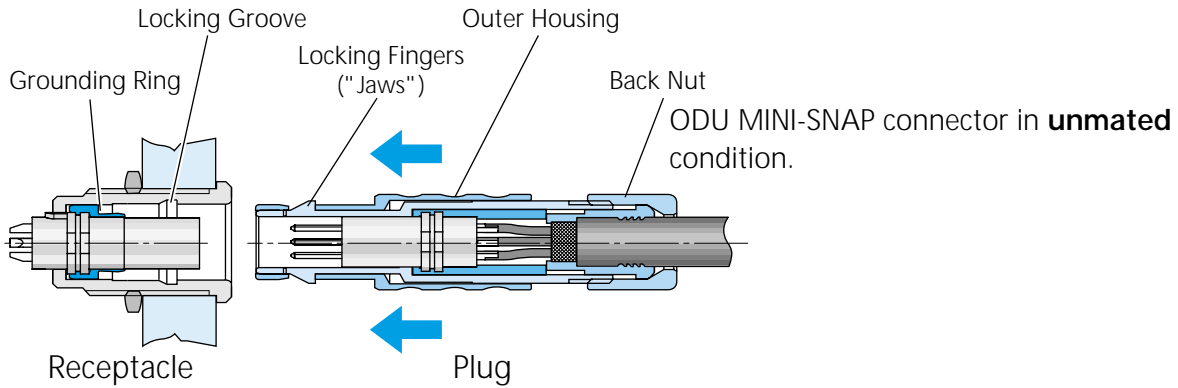

ODU MINI-SNAP

with LP-Locking Scheme in Cross Section

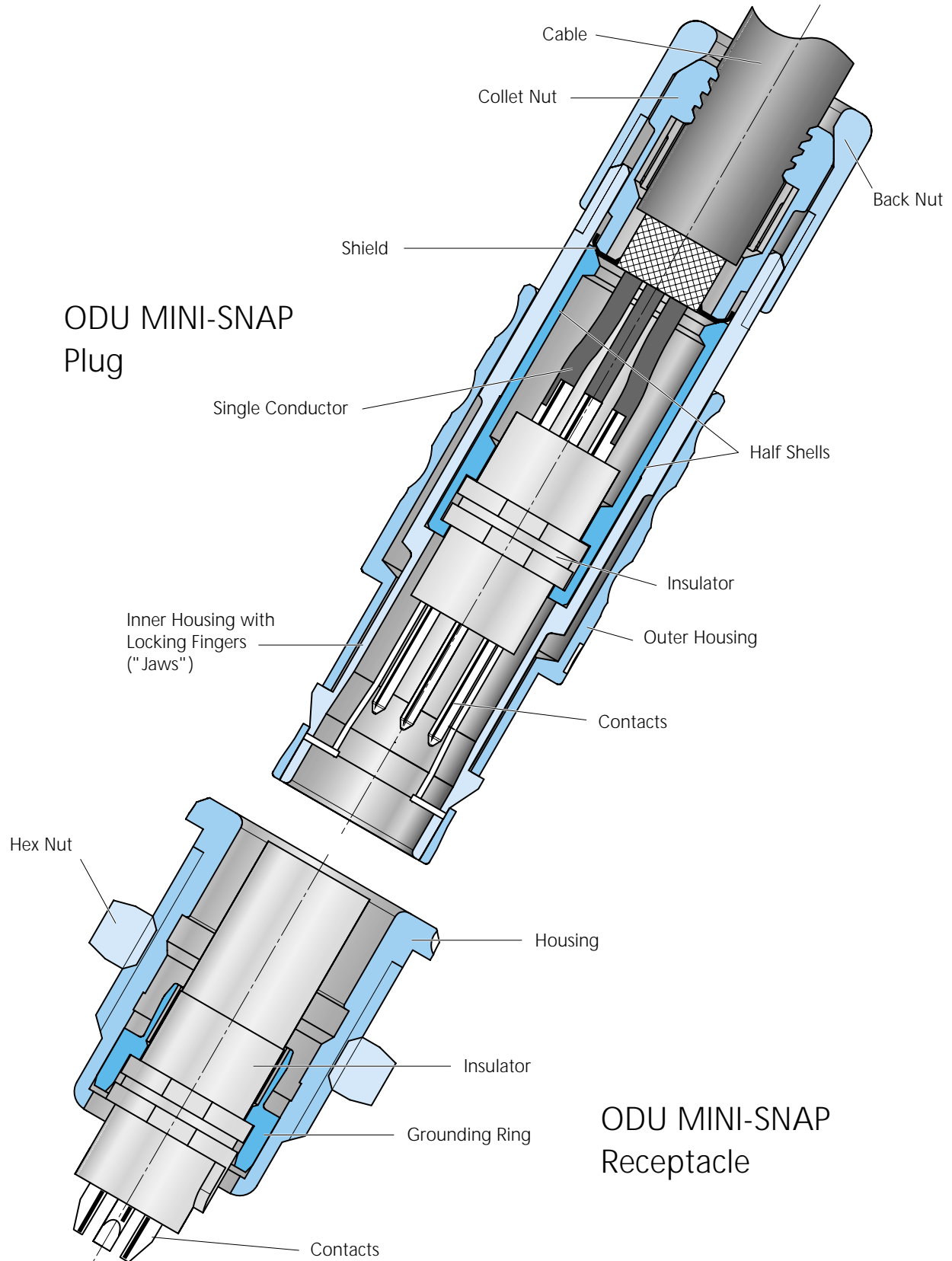

Available Housing Sizes

(Scale 1 : 1)

OD = Outside Diameter (Plug)

S = Size

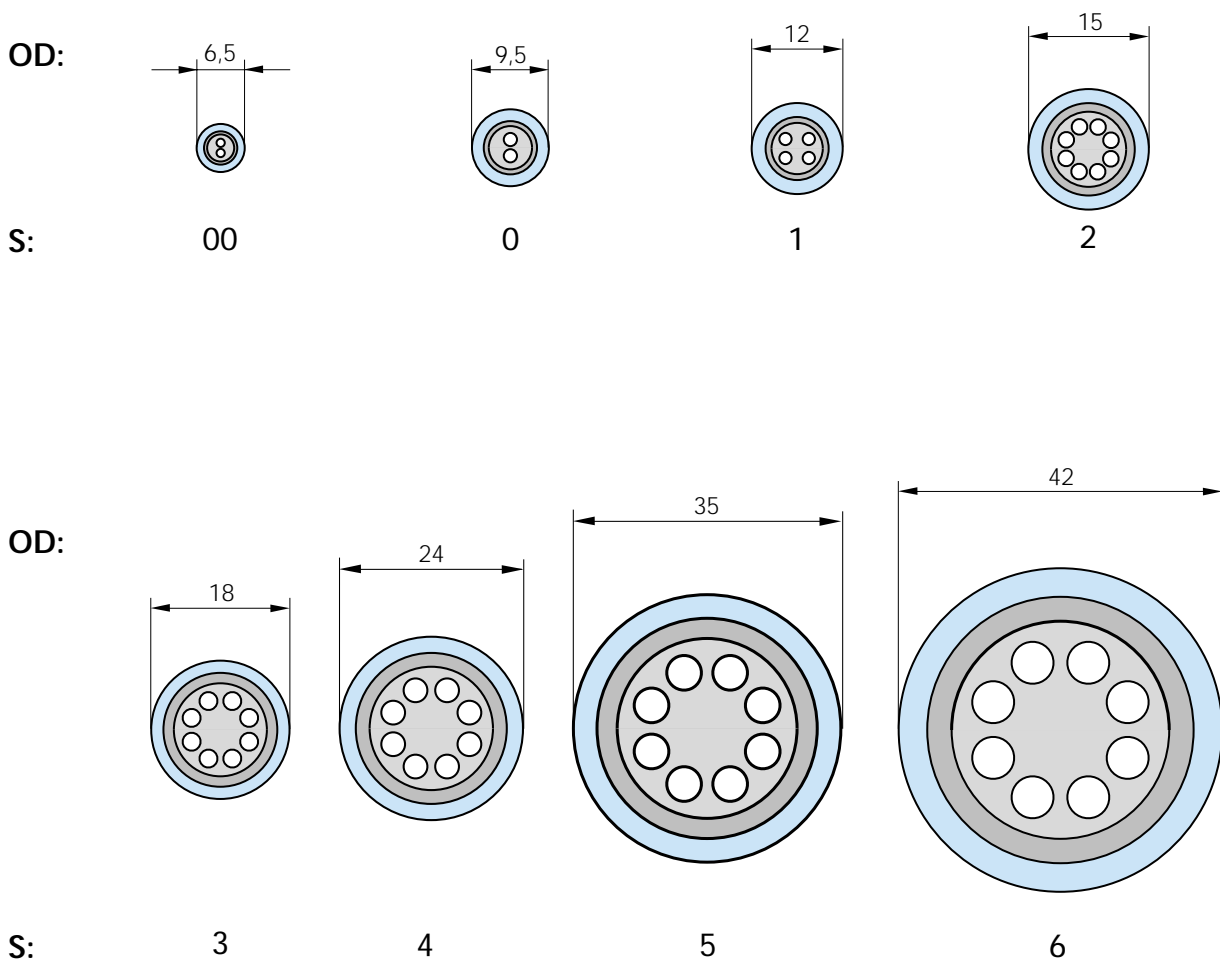

Part Number Key

The Part number key

1	2	3	4	5	6	7	8	9	10	11	12	13	14	15	16	17	18	19
			L			-									-			0

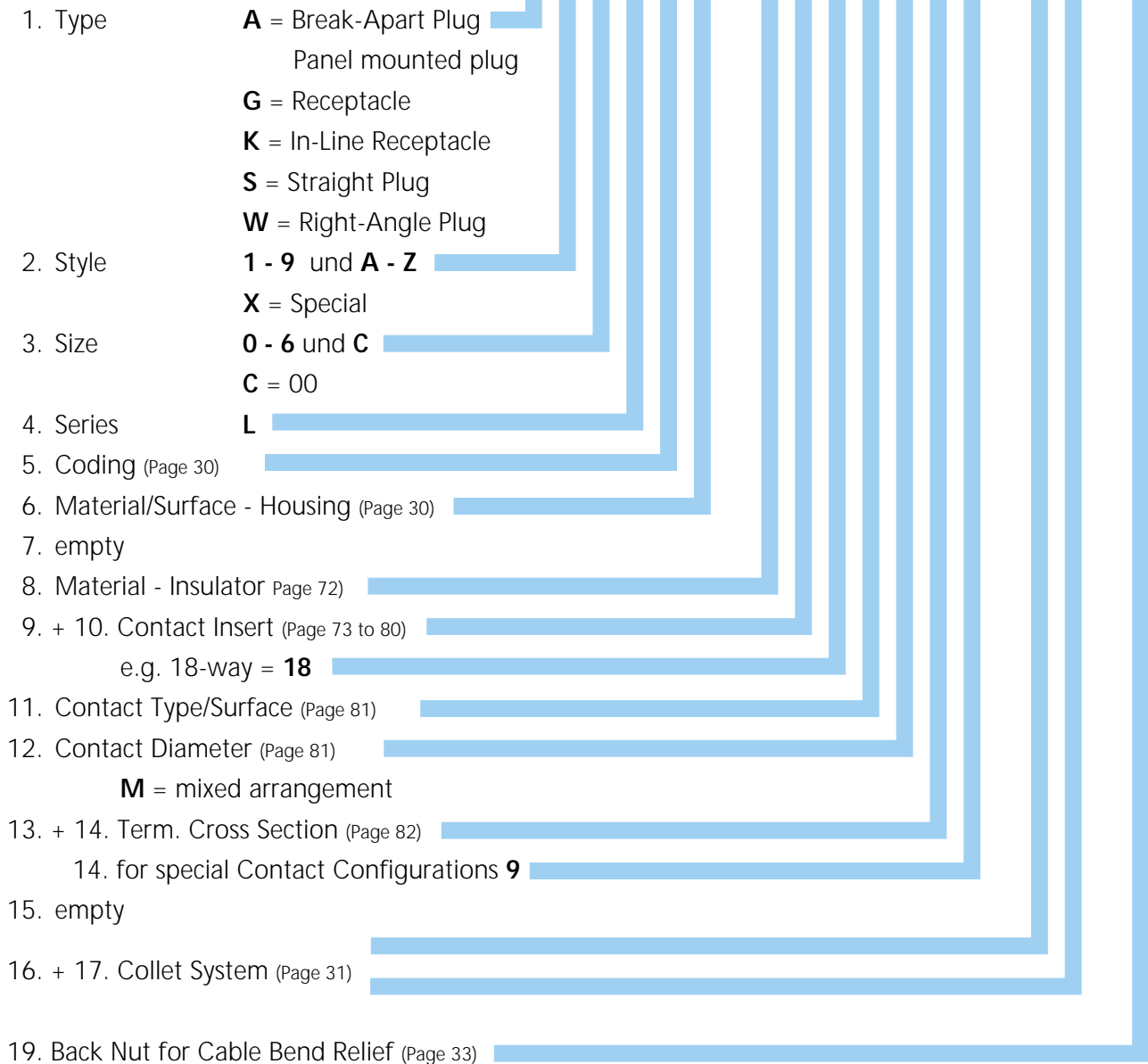

Example:

1	2	3	4	5	6	7	8	9	10	11	12	13	14	15	16	17	18	19
G	5	2	L	F	C	-	T	1	6	N	F	G	0	-	0	0	0	0

Receptacle - Style 5 - Size 2 - Series L - Coding 60° - Brass matt chromate Housing - PBT Insulator - 16pos. - Socket(crimp) 0,75 µm Au -Term. Cross Section AWG22

1	2	3	4	5	6	7	8	9	10	11	12	13	14	15	16	17	18	19
S	2	2	L	F	C	-	P	1	6	M	F	G	0	-	7	2	0	0

Plug - Style 2 - Size 2 - Series L - Coding 60° - Brass matt chromate Housing - PEEK Insulator - 16pos. - Pin (solder) 0,75 µm Au - Term. Cross Section AWG22 - Cable Diameter 6.0-7.2 mm -Back Nut for Silicone Cable Bend Relief (to order seperatly)

Part Number Key

1	2	3	4	5	6	7	8	9	10	11	12	13	14	15	16	17	18	19
			L			-								-				0



Straight Plug

(Suitable for all following receptacles and in-line receptacles)

- S 1** - IP 50 – with Standard Back Nut
- S 2** - IP 50 – with Back Nut for Cable Bend Relief*

S 1

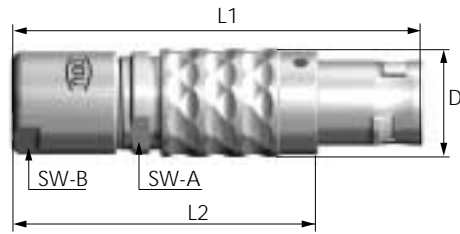

Contact configuration from page 73

S 2

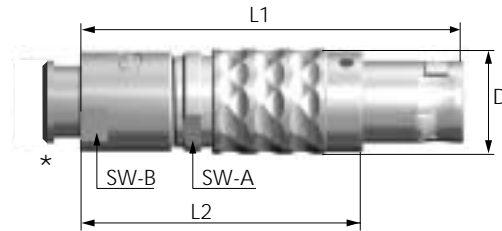

Size	Dimensions in mm				
	L1	L2	D	SW-A	SW-B
00	~ 28	~ 20	6,4	5,5	5
0	~ 37	~ 28	9	8	7
1	~ 47	~ 35	11,5	10	10
2	~ 50	~ 38	14,5	13	12 ²⁾
3	~ 61	~ 46	17,5	16	14
4	~ 76	~ 58	25	21	20
5 ¹⁾	~ 106	~ 81	35	31	30
6 ¹⁾	~ 104	~ 78	42	40	40

1) only S1

2) only for S1. S2 = 13

* Cable Bend Reliefs have to be ordered separately.
(see page 100 - 101)

Part Number Key

1	2	3	4	5	6	7	8	9	10	11	12	13	14	15	16	17	18	19
			L			-								-				0



Straight Plug with lanyard for fast demating

(Suitable for all following receptacles and in-line receptacles)

- S 7** - IP 50 – with Standard Back Nut
- S 8** - IP 50 – with Back Nut for Cable Bend Relief*



S 7

Contact configuration from page 73

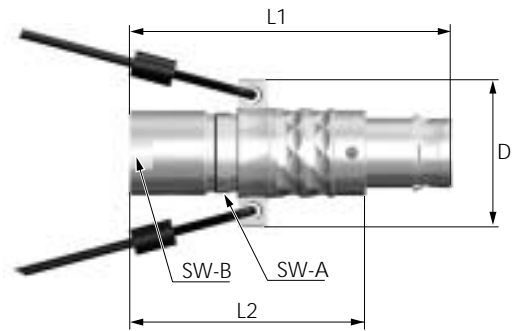

S 8

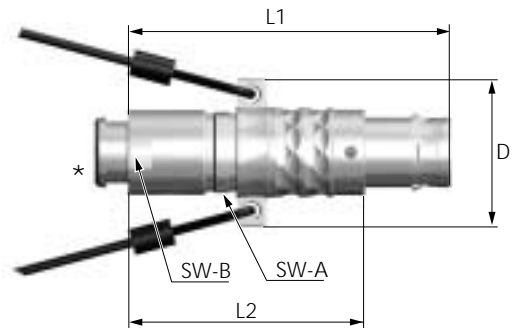

Size	Dimensions in mm				
	L1	L2	D	SW-A	SW-B
0	~ 36	~ 26	14,5	8	7
1	~ 47	~ 35	19	10	10
2	~ 50	~ 38	21	13	12
4	~ 76	~ 58	32	21	20
5	~ 106	~ 86	36,2	31	30

* Cable Bend Reliefs have to be ordered separately.
(see page 100 - 101)

Part number key

1	2	3	4	5	6	7	8	9	10	11	12	13	14	15	16	17	18	19
			L			-								-				0



Right-Angle Plug

(Suitable for all following receptacles and in-line receptacles)

- W 1** - IP 50 – with Standard Back Nut
- W 2** - IP 50 – with Back Nut for Cable Bend Relief*

W 1

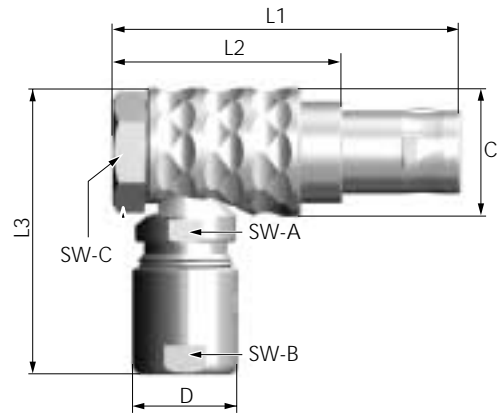

Contact configuration from page 73

W 2

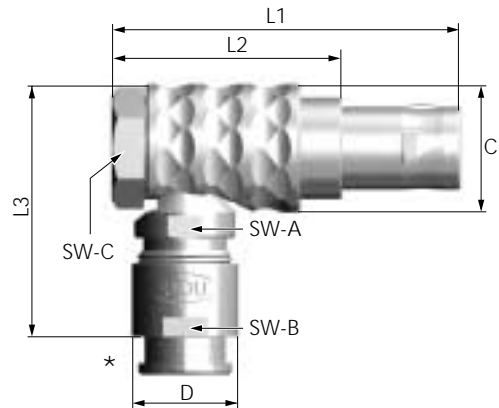

Size	Dimensions in mm							
	L1	L2	L3	C	D	SW-A	SW-B	SW-C
00	~ 24	16,3	~ 18,5	7,7	6,4	5,5	5	7
0	~ 30	16,5	~ 22,5	11	9	8	7	9
1	~ 36	20,9	~ 28,5	13,5	11	10	10	11
2	~ 41,5	25	~ 35	16,5	14	13	12	14
3	~ 50	~ 29,5	~ 36,5	19	16,5	15	14	17
4	~ 65	47,9	~ 52	25	23	21	20	22

* Cable Bend Reliefs have to be ordered separately.
(see page 100 - 101)

Part number key

1	2	3	4	5	6	7	8	9	10	11	12	13	14	15	16	17	18	19
			L			-								-				0



Right-angled Plug (Break-Apart version)

(Suitable for all following receptacles and in-line receptacles)

- W 3** - IP 50 – with Standard Back Nut
- W 4** - IP 50 – with Back Nut for Cable Bend Relief*

W 3

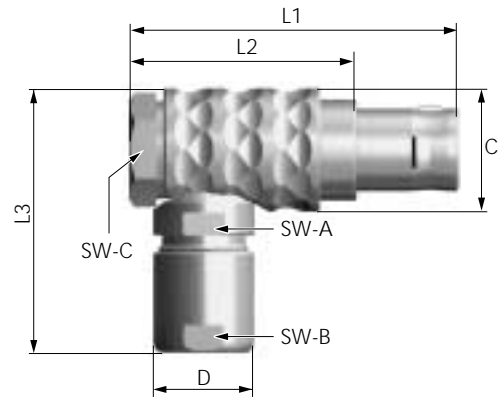

Contact configuration from page 73

W 4

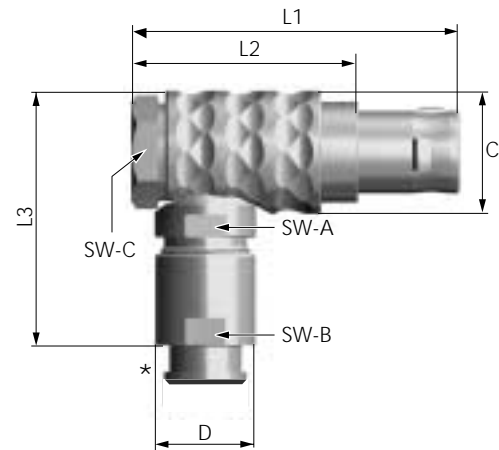

Size	Dimensions in mm							
	L1	L2	L3	C	D	SW-A	SW-B	SW-C
1	~ 36	25	~ 29	13,5	11	10	10	11
2	~ 41,5	29,5	~ 35	16,5	14	13	12	14

* Cable Bend Reliefs have to be ordered separately.
(see page 100 - 101)

Part number key

1	2	3	4	5	6	7	8	9	10	11	12	13	14	15	16	17	18	19
			L			-								-				0

Break-Apart-Plug (with latching)

- A 1** - IP 50 – with Standard Back Nut
- A 2** - IP 50 – with Back Nut for Cable Bend Relief*

(Suitable for all following receptacles and in-line receptacles)

A 1



Contact configuration from page 73

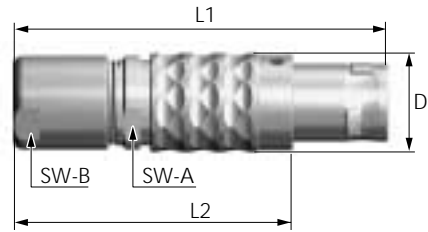

A 2

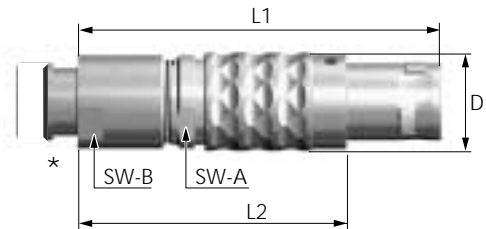

Size	Dimensions in mm				
	L1	L2	D	SW-A	SW-B
00	~ 28	~ 20	6,4	5,5	5
0	~ 36	~ 26	9,0	8	7
1	~ 43	~ 32	11,5	10	10
2	~ 50	~ 38	14,5	13	12

Connector can be separated by pulling the cable.

* **Cable Bend Reliefs have to be ordered separately.**
(see page 100 - 101)

Part number key

1	2	3	4	5	6	7	8	9	10	11	12	13	14	15	16	17	18	19
			L			-								-				0



Break-Apart-Plug (without latching)

(Suitable for all following receptacles and in-line receptacles)

A 5

- IP 50 – with Standard Back Nut

A 6

- IP 50 – with Back Nut for Cable Bend Relief*

A 5

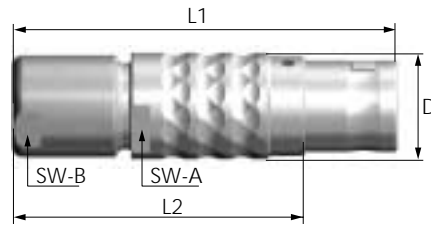

Contact configuration from page 73

A 6

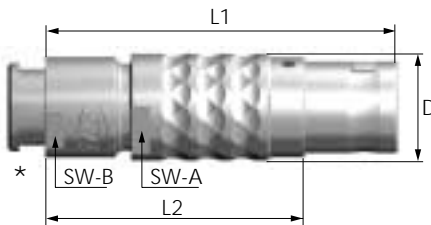

Size	Dimensions in mm				
	L1	L2	D	SW-A	SW-B
00	~ 28	~ 20	6,4	5,5	5
0	~ 34	~ 23	8,9	8	7
1	~ 43	~ 32	11,5	10	10
3	~ 61	~ 46	18	16	14

Connector can be separated by pulling the cable.

* Cable Bend Reliefs have to be ordered separately.
(see page 100 - 101)

Part number key

1	2	3	4	5	6	7	8	9	10	11	12	13	14	15	16	17	18	19
			L			-								-			0	0

Panel-Mounted Plug

(Suitable for all following receptacles and in-line receptacles)

A A - IP 50 – with hex nut, **non-latching**, installation from front of panel

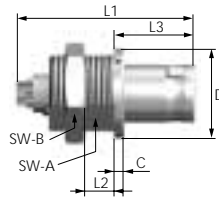

Technical Data

- IP 50 in mated condition
- anti-rotation feature
- contact configuration and PCB-Layout from page 73

Size	Dimensions in mm							Panel cut-out
	L1	L2	L3	C	D	SW-A	SW-B	
00	17,5	4,5	8	1	8	6,3	9	SW 6,4 / Ø 7,1
0	21	3,5	10	1,2	10	8,2	11	SW 8,3 / Ø 9,1
1	26,8	7	10,8	1,5	14	10,5	14	SW 10,6 / Ø 12,1
2	27,5	7	12	1,8	18	13,5	17	SW 13,6 / Ø 15,1
3	34,5	9	15	2	22	16,5	22	SW 16,6 / Ø 18,1
4	37,1	8	18	2,5	28	23,5	30	SW 23,6 / Ø 25,1

Created to build up a docking connection between 2 instruments (E.g. a charging station).

A B - IP 50 – with hex nut, **latching**, installation from front of panel

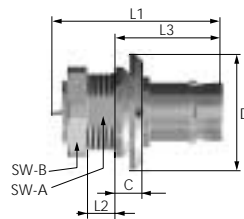

Technical Data

- IP 50 in mated condition
- anti-rotation feature
- contact configuration and PCB-Layout from page 73

Size	Dimensions in mm								Panel cut-out
	L max.	L1	L2	L3	M	D2	SW-A	SW-B	
1	26,2	24	4	17	12x1,0	17,9	10,5	14	SW 10,6 / Ø 12,1

Created to build up a docking connection between 2 instruments (E.g. a charging station).

A D - IP 68 – with hex nut, **non-latching**, installation from front of panel

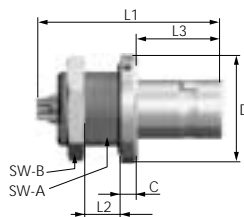

Technical Data

- IP 68 in mated condition
- anti-rotation feature
- contact configuration and PCB-Layout from page 73

Size	Dimensions in mm							Panel cut-out
	L1	L2	L3	C	D	SW-A	SW-B	
0	23,5	5,5	10	2	13	8,2	11	SW 8,3 / Ø 9,1
2	28,8	7	12	2,8	19,5	13,5	17	SW 13,6 / Ø 15,1
3	31,55	7,5	15	3	23,9	16,5	22	SW 16,6 / Ø 18,1

Created to build up a docking connection between 2 instruments (E.g. a charging station).

Part number key

1	2	3	4	5	6	7	8	9	10	11	12	13	14	15	16	17	18	19
			L			-								-				0

In-Line Receptacle

- K 1** - IP 50 – with Standard Back Nut
- K 2** - IP 50 – with Back Nut for Cable Bend Relief*

K 1



Contact configuration from page 73

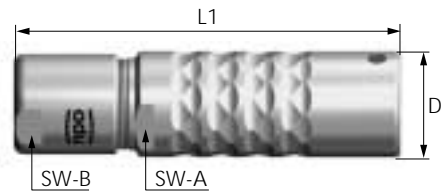

K 2

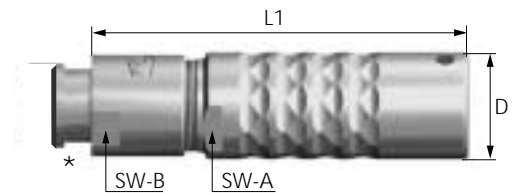

Size	Dimensions in mm			
	L1	D	SW-A	SW-B
00	~ 27	6,4	5,5	5
0	~ 34,5	9,4	8	7
1	~ 41	11,5	10	10
2	~ 47	14,5	13	12
3	~ 56	18	16	15
4	~ 74	23,5	21	20

* Cable Bend Reliefs have to be ordered separately.
(see page 100 - 101)

ODU MINI-SNAP In-line Receptacle connect to plug for cable-to-cable connection.

Part number key

1	2	3	4	5	6	7	8	9	10	11	12	13	14	15	16	17	18	19
			L			-								-				00

¹⁾ L1 = Maximum Length incl. Contact Insert
²⁾ L3 =Length of Housing

Receptacle

G 1 Style 1 – ODU MINI-SNAP RECEPTACLE IP 50, installation from front of panel

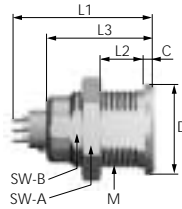

Technical Data

- IP 50
- anti-rotation feature
- contact configuration and PCB-Layout from page 73

Size	Dimensions in mm									Panel cut-out
	¹⁾ L1	L2	²⁾ L3	M	D	SW-A*	SW-B	C	SW	
00	~ 16,0	~ 7,0	12,0	7x0,5	8,0	9,0	6,3	1,0	SW 6,4 / Ø 7,1	
0	~ 19,5	~ 9,0	14,5	9x0,5	10,0	11,0	8,2	1,5	SW 8,3 / Ø 9,1	
1	~ 24,0	~ 8,0	16,5	12x1	14,0	14,0	10,5	1,5	SW 10,6 / Ø 12,1	
2	~ 27,5	~10,0	18,5	15x1	18,0	17,0	13,5	2,0	SW 13,6 / Ø 15,1	
3	~ 33,0	~13,0	22,5	18x1	22,0	22,0	16,5	2,0	SW 16,6 / Ø 18,1	
4	~ 36,0	~13,0	27,5	25x1	28,0	30,0	23,5	2,5	SW 23,6 / Ø 25,1	
5*	~ 43,5	~14	34,0	35x1	40,0	-	33,5	3,0	SW 33,6 / Ø 35,1	
6	~ 46,0	~18,0	33,0	42x1,5	48,0	48,0	40,0	3,5	SW 40,1 / Ø 42,1	

* Attention: Size 5 is with a slotted nut instead of a hex nut

G 5 Style 5 – ODU MINI-SNAP RECEPTACLE IP 50, CONTINUOUS THREAD, installation from rear or front of panel. Front extension adjustable

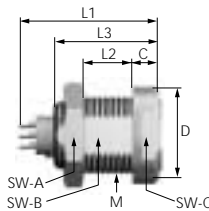

Technical Data

- IP 50
- anti-rotation feature
- contact configuration and PCB-Layout from page 73

Size	Dimensions in mm									Panel cut-out
	¹⁾ L1	L2	²⁾ L3	M	D	SW-A*	SW-B	SW-C	C	
00	~16,0	~ 6,0	12,0	7x0,5	9,0	9,0	6,3	8,0	2,0	SW 6,4 / Ø 7,1
0	~19,5	~ 8,0	14,5	9x0,5	11,5	11,0	8,2	10,0	2,5	SW 8,3 / Ø 9,1
1	~24,0	~ 8,0	16,5	12x1	15,0	14,0	10,5	13,0	4,0	SW 10,6 / Ø 12,1
2	~27,5	~10,0	18,5	15x1	20,0	17,0	13,5	17,0	4,0	SW 13,6 / Ø 15,1
3	~33,0	~14,0	22,5	18x1	23,0	22,0	16,5	20,0	5,0	SW 16,3 / Ø 18,1
4	~35,0	~10,5	27,0	25x1	29,9	30,0	23,5	27,0	4,5	SW 23,6 / Ø 25,1
5*	~43,5	~12,0	34,0	35x1	42,0	33,5	-	39,0	5,0	SW 33,6 / Ø 35,1

* Attention: Size 5 is with a slotted nut instead of a hex nut

Part number key

1	2	3	4	5	6	7	8	9	10	11	12	13	14	15	16	17	18	19
			L			-								-				00

¹⁾ L1 = Maximum Length incl. Contact Insert

²⁾ L3 =Length of Housing

↑↑ Receptacle

G 6 Style 6 – ODU MINI-SNAP RECEPTACLE IP 50, with slotted nut, installation from rear or front of panel

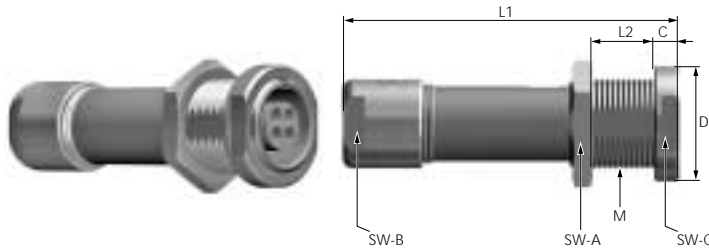

Technical Data

- IP 50
- anti-rotation feature
- contact configuration from page 73

Size	Dimensions in mm								Panel cut-out
	¹⁾ L1	L2	M	D	SW-A	SW-B	SW-C	C	
0	~35,0	~ 6,0	9x0,5	11,5	11,0	7,0	10,0	2,5	SW 8,3 / Ø 9,1
1	~41,0	~ 5,0	12x1	14,9	14,0	10,0	13,0	4,0	SW 10,6 / Ø 12,1
2	~48,0	~ 6,5	15x1	19,9	17,0	12,0	17,0	3,8	SW 13,5 / Ø 15,1

G 8 Style 8 – ODU MINI-SNAP WATERTIGHT RECEPTACLE IP 68*, with slotted nut, installation from rear of panel

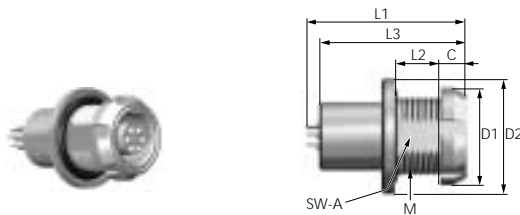

Technical Data

- IP 68 to the panel in mated or unmated condition
- anti-rotation feature
- contact configuration and PCB-Layout from page 73
- nutdriver for slotted mounting nut, Page 112

Size	Dimensions in mm								Panel cut-out
	¹⁾ L1	L2	²⁾ L3	M	D1	D2	SW-A	C	
0	~22,5	6,0	18,5	9x0,5	12	14	8,2	3	SW 8,3 / Ø 9,1
1	~26,0	6,0	22,5	12x1	15,0	17,9	10,5	4,0	SW 10,6 / Ø 12,1
2	~28,0	6,0	23,0	15x1	19,0	19,9	13,5	4,0	SW 13,6 / Ø 15,1
3	~30,0	8,5	26,5	18x1	23,0	23,9	16,5	5,0	SW 16,6 / Ø 18,1

* Reference: Potted Receptacle please see page 125

G A Style A – ODU MINI-SNAP RECEPTACLE IP 50, with round nut, installation from rear of panel

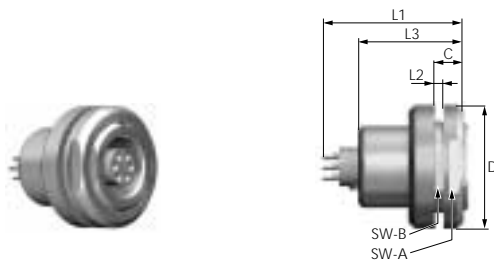

Technical Data

- IP 50
- anti-rotation feature
- contact configuration and PCB-Layout from page 73

Size	Dimensions in mm								Panel cut-out
	¹⁾ L1	L2	²⁾ L3	M	D	SW-A	SW-B	C	
1	~ 26,0	~ 2,0	16,5	14x1	19,0	17,0	12,0	5,0	SW 12,1 / Ø 14,1
2	~ 29,0	~ 2,0	18,5	16x1	21,9	19,0	15,0	5,0	SW 15,1 / Ø 16,1
3	~ 33,0	~ 2,0	25,0	20x1	26,9	24,0	18,0	6,0	SW 18,1 / Ø 20,1
6	~ 46,0	~ 5,0	33,0	42x1,5	50,0	45,0	40,0	11	SW 40,1 / Ø 42,1

Part number key

1	2	3	4	5	6	7	8	9	10	11	12	13	14	15	16	17	18	19
			L			-								-			0	0

¹⁾ L1 = Maximum Length incl. Contact Insert
²⁾ L3 = Length of Housing

Receptacle

G F Style F* – ODU MINI-SNAP RIGHT-ANGLE RECEPTACLE (without thread)



Technical Data

- IP 50
- Contact configuration from page 73
- Standard-Surface Nickel (Ni)

Size 0 / (1)

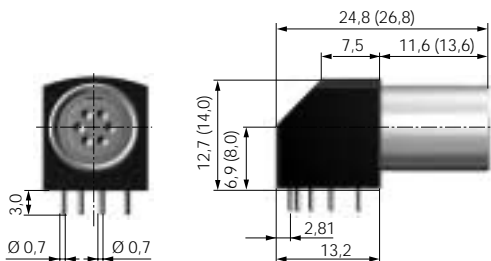

PCB-Layout

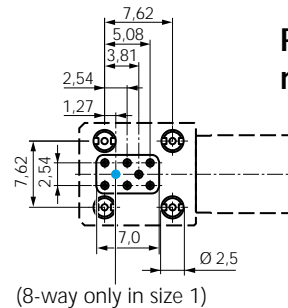

Receptacle for Screw-mounting on the PCB

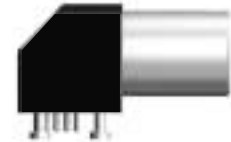

* Maximum positions in size 00: 4-way, please order drawing
 Maximum positions in size 0: 7-way
 Maximum positions in size 1: 10-way
 Inserts with more positions on request

Order informations to the Screw mounting please see page 32

G G Style G* – ODU MINI-SNAP RIGHT-ANGLE RECEPTACLE (with thread)

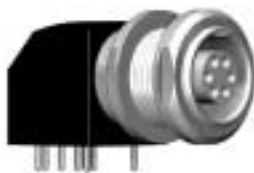

Technical Data

- IP 50
- Contact configuration from page 73
- Standard-Surface Nickel (Ni)

Size 0 / (1)

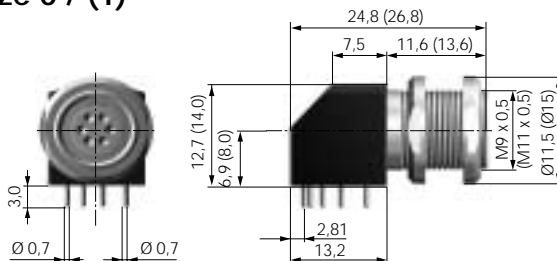

PCB-Layout

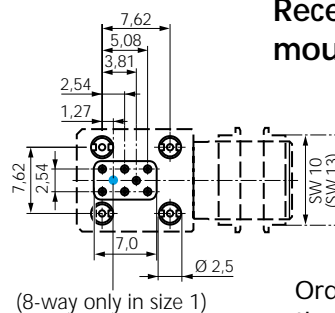

Receptacle for Screw-mounting on the PCB



* Maximum positions in size 0: 7-way
 Maximum positions in size 1: 10-way
 Inserts with more positions on request

Order informations to the Screw mounting please see page 32

Part number key

1	2	3	4	5	6	7	8	9	10	11	12	13	14	15	16	17	18	19
			L			-								-				00

¹⁾ L1 = Maximum Length incl. Contact Insert

²⁾ L3 = Length of Housing

Receptacle

G H

Style H – ODU MINI-SNAP **PROTRUDENT RECEPTACLE IP 50**, with low rear profile

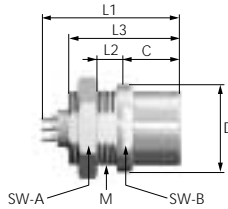

Technical Data

- IP 50
- anti-rotation feature
- contact configuration and PCB-Layout from page 73

Size	Dimensions in mm								Panel cut-out
	¹⁾ L1	L2	²⁾ L3	M	D	SW-A	SW-B	C	
00	~ 16,0	~ 2,5	12,5	7x0,5	9,0	9,0	6,3	8,0	SW 6,4 / Ø 7,1
0	~ 21,5	~ 3,5	15,0	9x0,5	11,5	11,0	8,2	9,0	SW 8,3 / Ø 9,1
1	~ 24,0	~ 4,5	17,5	12x1	14,0	14,0	10,0	10,0	SW 10,6 / Ø 12,1
2	~ 26,0	~ 6,0	19,5	15x1	18,0	17,0	13,5	11,0	SW 13,6 / Ø 15,1

G K

Style K – ODU MINI-SNAP **Receptacle IP 50**, with round nut, installation from rear of panel

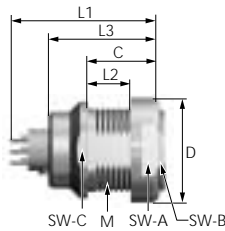

Technical Data

- IP 50
- anti-rotation feature
- contact configuration and PCB-Layout from page 73

Size	Dimensions in mm									Panel cut-out
	¹⁾ L1	L2	²⁾ L3	M	D	SW-A	SW-B	SW-C	C	
0	~ 19,5	~ 3,8	14,5	9x0,5	11,5	10,0	8,2	9,0	6,3	SW 8,3 / Ø 9,1
1	~ 24,0	~ 7,0	16,5	12x1	15,0	13,0	10,5	13,0	11,0	SW 10,6 / Ø 12,1
2	~ 27,5	~ 5,0	18,5	15x1	20,0	17,0	13,5	15,0	9,0	SW 13,6 / Ø 15,1
3	~ 31,0	~ 7,0	22,5	18x1	23,0	20,0	16,5	20,0	12,0	SW 16,6 / Ø 18,1
4	~ 35,0	~ 10,0	27,0	25x1	29,9	27,0	23,5	27,0	14,5	SW 23,6 / Ø 25,1

G L

Style L – ODU MINI-SNAP **Receptacle IP 68**, installation from front of panel

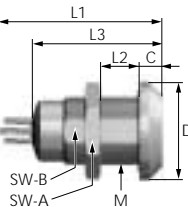

Technical Data

- IP 68 in reference to the tightness of the end device
- anti-rotation feature
- contact configuration and PCB-Layout from page 73

Size	Dimensions in mm								Panel cut-out
	L1*	L2	L3*	M	D	SW-A	SW-B	C	
00	~ 18	~ 8,0	14,5	7x0,5	11,0	9,0	6,3	1,5	SW 6,4 / Ø 7,1
0	~ 21	~ 7,5	16,5	9x0,5	13,0	10,0	11,0	3,0	SW 8,3 / Ø 9,1
1	~ 27	~ 9,0	21,5	12x1	16,0	13,0	14,0	4,5	SW 10,6 / Ø 12,1
2	~ 29	~ 8,0	24,0	15x1	20,0	17,0	17,0	4,0	SW 13,6 / Ø 15,1

* Reference: Potted receptacle please see page 127

Part number key

1	2	3	4	5	6	7	8	9	10	11	12	13	14	15	16	17	18	19
			L			-								-			0	0

¹⁾ L1 = Maximum Length incl. Contact Insert
²⁾ L3 =Length of Housing

Receptacle

G P Style P – ODU MINI-SNAP PCB Receptacle IP 50

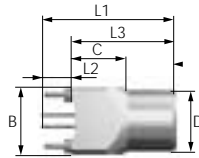

Technical Data

- IP 50
- contact configuration and PCB-Layout from page 73

Size	Dimensions in mm					
	L1	L2	L3	B	C	D
0	19,5	3,8	15,0	10,0	8,0	9,0
1	23,0	4,0	19,0	12,0	8,0	11,0

PCB-layout on request

Details for the Part Number Key:

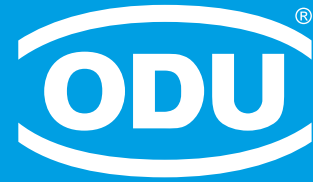
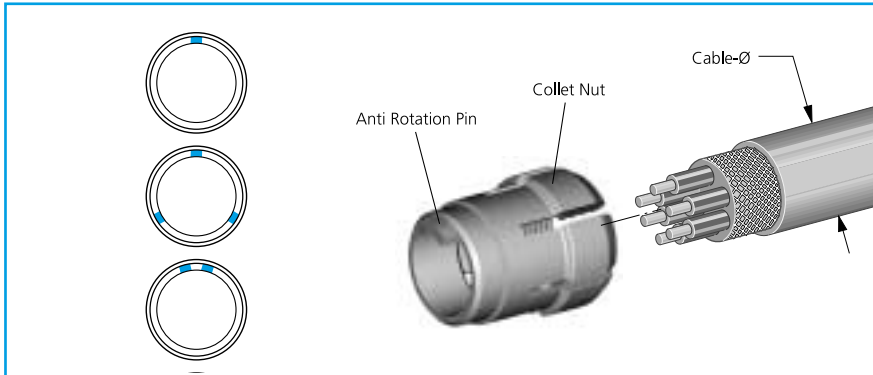

Keyings
Housing Materials / Surfaces
Collet System
Bend Protection Sleeves



Coding

Part number key

1	2	3	4	5	6	7	8	9	10	11	12	13	14	15	16	17	18	19
			L		-									-				0



	Angle	Receptacle Front View	Size							
			00	0	1	2	3	4	5	6
O	0°		●	●	●	●	●	●	●	
O	0°									●
A	30°		●	●	●	●	●	○		
B	37,5°					●	●	○		
C	45°					●	●	○		
C	-45°		●	●	●					
F	60°		●	●	●	●	●	○		
J	90°			●	●					
K	95°					●	●	○		
Q	120°					●	●	○		
V	135°			○	●					
W	145°			○	○	●	○	○		
Y	155°			●	●					

● Standard
○ On Request

Housing Materials / Surfaces

Part number key

1	2	3	4	5	6	7	8	9	10	11	12	13	14	15	16	17	18	19
			L			-								-				



C	Standard Cu-alloy / matt chromate
N	Special materials and surfaces on request. Cu-alloy / nickel
S	Cu-alloy / black chromate

Collet System

Part number key

1	2	3	4	5	6	7	8	9	10	11	12	13	14	15	16	17	18	19
			L			-								-				0

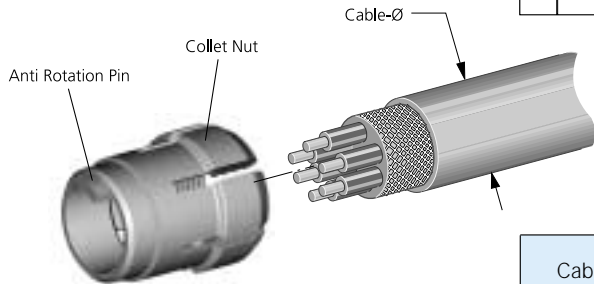

Cable diameter in mm	Size									
	00	0	1	2	3	4	5	6		
> 0,5 - 1,0	●								1	0
> 1,5 - 2,0	●								2	0
> 1,5 - 2,2		●							2	2
> 2,0 - 2,5	●								2	5
> 2,5 - 3,0	●								3	0
> 2,0 - 3,2		●	●	●					3	2
> 3,0 - 3,5	●								3	5
> 3,0 - 4,2		●	●	●	●				4	2
> 4,0 - 5,2		●	●	●	●				5	2
> 5,0 - 5,6		○							5	6
> 5,0 - 6,2			●	●	●	●			6	2
> 6,0 - 7,2			●	●	●	●			7	2
> 7,0 - 7,7			○						7	7
> 7,0 - 8,0						●			8	0
> 7,0 - 8,2				●	●				8	2
> 8,0 - 9,2				●	●	●			9	2
> 9,0 - 9,9				○					9	9
> 9,0 - 10,2					●				0	2
> 9,1 - 10,5						●			0	2
> 10,0 - 11,0						●			1	1
> 10,0 - 11,2					●				1	2
> 11,0 - 11,9					○	●			1	9
> 12,0 - 13,0						●		●	1	3
> 14,0 - 15,0							●	●	1	5
> 15,0 - 16,0							●		1	6
without collet system									0	0

○ This diameters are not deliverable for applications with cable bend relief.

Useable: for all Plugs and In-Line Receptacles and Receptacle style 6.

Application: **Collet nut** for strain relief.

Right-Angled Print Contacts in the Receptacle
Part number key

1	2	3	4	5	6	7	8	9	10	11	12	13	14	15	16	17	18	19
			L			-								-			0	0

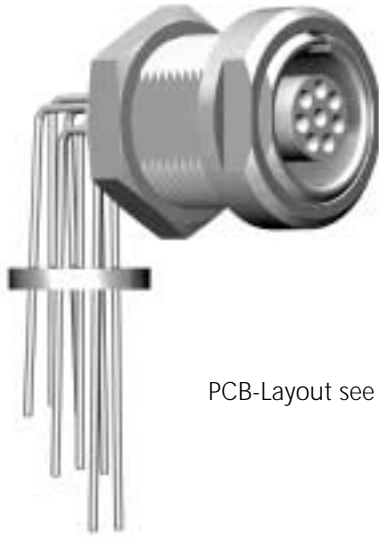

PCB-Layout see Page 84 - 87

Right-Angled Print Contact

A

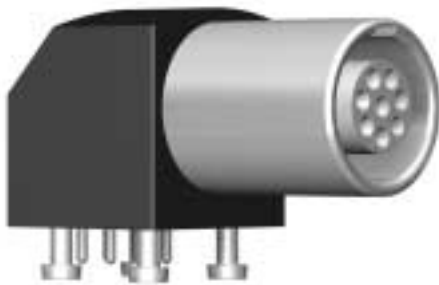

Receptacle style F and G for
Screw Mounting
(see page 26)

S

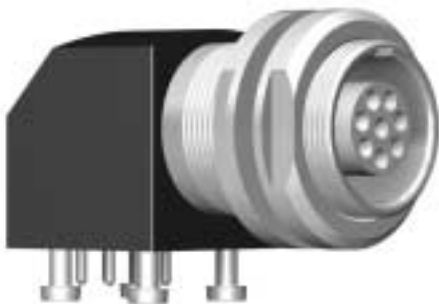

Max. tightening torque of the screws M1,4: 0,1 Nm

Definition of the Back Nut

(Straight- Angled- Break Apart Plugs, Inline Receptacles, Receptacles Style 6)

Part number key

1	2	3	4	5	6	7	8	9	10	11	12	13	14	15	16	17	18	19
			L			-								-			0	



Standard Back Nut

0



Back Nut for Silicon Cable Bend Reliefs

S



Back Nut for PUR Cable Bend Reliefs

0



Inserts Series L, K, B

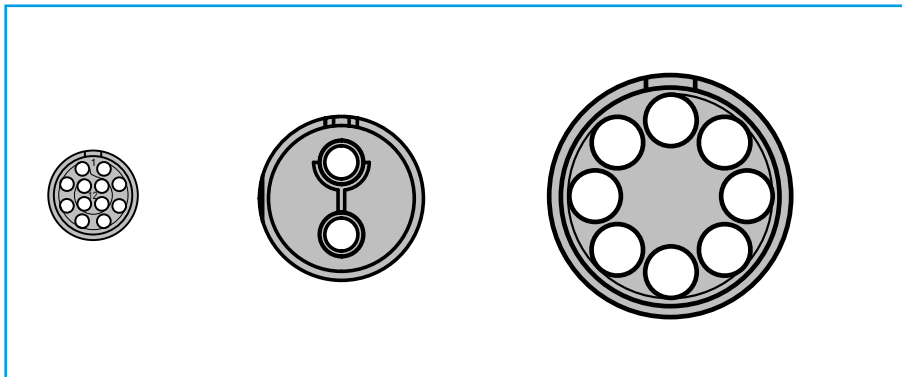

PCB and solder contacts are factory-installed in the insulation body.

Crimp contacts are shipped separately





Insulation Body Material

Part number key

1	2	3	4	5	6	7	8	9	10	11	12	13	14	15	16	17	18	19
						-								-			0	



T

PBT

P

PEEK

Additional materials on request

Turned Contacts

Article Number	PBT	PEEK
Solder Termination	✓	✓
Crimp Termination	✓	✓*
PCB Termination	✓	✓

✓ = available

* = PEEK insulators have crimp contacts with clip

Size 00

Part number key

1	2	3	4	5	6	7	8	9	10	11	12	13	14	15	16	17	18	19
		C				-								-				

Standard Contact Configuration	Size	Positions	Positions	Contact Ø mm	Nominal Signal Contact Current Load in A (Derating Factor see page 130)	Test Voltage acc. VDE 0627:1986-06 (kVeff)	Test Voltage acc. SAE AS13441:1998 method 3001.1 (kVeff)	Nominal Voltage acc. SAE AS13441:1998 method 3001.1 (kVrms) ¹⁾	Termination			View on termination side	
									Solder	Crimp (tools for assembling see page 106)	Print (PCB Layout see page 84)	Pin Part	Socket
C		0	2	0,5	5	0,750	1,100	0,366	●	●			
C		0	3	0,5	5	0,750	1,100	0,366	●	●			
C		0	4	0,5	5	0,750	0,900	0,300	●	●			

Attention: Inserts in Size 00 are only in PEEK available.

1) Nominal Voltage acc. SAE AS 13441:1998 method 3001.1 meet the MIL-STD 1344, method 3001, Test acc. IEC 60512 test 4a.
Method of calculation, utilization warning and Proposals see page 129

Size 0

Part number key

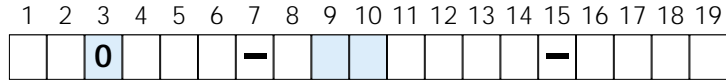

	Size	Positions		Contact Ø mm	Nominal Signal Contact Current Load in A (Derating factor see page 130)	Test Voltage acc. VDE 0627:1986-06 (kVeff)	Test Voltage acc. SAE AS13441:1998 method 3001.1 (kVeff)	Nominal Voltage acc. SAE AS13441:1998 method 3001.1 (kVrms) ¹⁾	Termination			View on termination side	
									Solder	Crimp (tools for assembling see page 106)	Print (PCB Layout see page 84)	Pin Part	Socket
Standard Contact Configuration	0	0	2	0,9	10	0,875	1,500	0,500	●	●	●		
	0	*	3	0,9	10	0,875	1,200	0,400	●	●	●		
	0		4	0,7	7	0,875	0,900	0,300	●	●	●		
	0	*	5	0,7	7	0,750	1,100	0,366	●	●	●		
	0	*	6	0,5	5	0,750	0,900	0,300	●		●		
	0		7	0,5	5	0,750	0,900	0,300	●		●		
	0		9	0,5	5	0,750	0,600	0,200	●		●		

* Please note that these inserts are only available in PEEK.

1) Nominal Voltage acc. SAE AS 13441:1998 method 3001.1 meet the MIL-STD 1344, method 3001, Test acc. IEC 60512 test 4a. Method of calculation, utilization warning and Proposals see page 129.

Size 1

Part number key

1	2	3	4	5	6	7	8	9	10	11	12	13	14	15	16	17	18	19
		1				-								-				

Standard Contact Configuration	Size	Positions		Contact Ø mm	Nominal Signal Contact Current Load in A (Derating Factor see page 130)	Test Voltage acc. VDE 0627:1986-06 (kVeff)	Test Voltage acc. SAE AS13441:1998 method 3001.1 (kVeff)	Nominal Voltage acc. SAE AS13441:1998 method 3001.1 (kVrms) ¹⁾	Termination			View on termination side	
		Solder	Climp (tools for assembling see page 106)						Print (PCB Layout see page 85)	Pin part	Socket		
	1	0	2	1,3	14	1,000	1,650	0,550	●	●	●		
	1	0	3	1,3	14	1,000	1,500	0,500	●	●	●		
	1	0	4	0,9	10	0,875	1,500	0,500	●	●	●		
	1	0	5	0,9	10	0,875	1,350	0,450	●	●	●		
	1	0	6	0,7	7	0,875	1,200	0,400	●	●	●		
	1	0	7	0,7	7	0,875	1,200	0,400	●	●	●		
	1	*	0 8	0,7	7	0,750	1,000	0,333	●		●		
	1		1 0	0,5	5	0,750	1,000	0,333	●		●		
	1	*	1 4	0,5	5	0,750	0,900	0,300	●		●		

* Please note that these inserts are only available in PEEK.

1) Nominal Voltage acc. SAE AS 13441:1998 method 3001.1 meet the MIL-STD 1344, method 3001, Test acc. IEC 60512 test 4a. Method of calculation, utilization warning and Proposals see page 129

Size 2

Part number key

1	2	3	4	5	6	7	8	9	10	11	12	13	14	15	16	17	18	19
	2					-								-				

Standard Contact Configuration	Size	Positions		Contact Ø mm	Nominal Signal Contact Current Load in A (Derating factor see page 130)	Test Voltage acc. VDE 0627:1986-06 (kVeff)	Test Voltage acc. SAE AS13441:1998 method 3001.1 (kVeff)	Nominal Voltage acc. SAE AS13441:1998 method 3001.1 (kVrms) ¹⁾	Termination			View on termination side	
		Solder	Crimp (tools for assembling see page 106)						Print (PCB Layout see page 86)	Pin part	Socket		
	2	0	2	2,0	22	1,500	2,100	0,700	●	●	●		
	2	0	3	1,6	17	1,500	2,400	0,800	●	●	●		
	2	0	4	1,3	14	1,500	1,950	0,650	●	●	●		
	2	0	5	1,3	14	1,250	1,800	0,600	●	●	●		
	2	0	6	1,3	14	1,000	1,500	0,500	●	●	●		
	2	0	7	1,3	14	1,000	1,800	0,600	●	●	●		
	2	0	8	0,9	10	1,000	1,500	0,500	●	●	●		
	2	1	0	0,9	10	1,000	1,500	0,500	●	●	●		
	2	1	2	0,7	7	0,875	1,350	0,450	●	●	●		

Continue next page

1) Nominal Voltage acc. SAE AS 13441:1998 method 3001.1 meet the MIL-STD 1344, method 3001, Test acc. IEC 60512 test 4a. Method of calculation, utilization warning and Proposals see page 129

Size 2 (Continue)

Part number key

1	2	3	4	5	6	7	8	9	10	11	12	13	14	15	16	17	18	19
	2					-								-				

Standard Contact Configuration	Size	Positions		Contact Ø mm	Nominal Signal Contact Current Load in A (Derating Factor see page 130)	Test Voltage acc. VDE 0627:1986-06 (kVeff)	Test Voltage acc. SAE AS13441:1998 method 3001.1 (kVeff)	Nominal Voltage acc. SAE AS13441:1998 method 3001.1 (kVrms) ¹⁾	Termination			View on termination side	
		1	4						Solder	Crimp (tools for assembling see page 106)	Print (PCB Layout see page 86)	Pin part	Socket
2	2	1	4	0,7	7	0,875	1,200	0,400	●	●	●		
2	2	1	6	0,7	7	0,875	1,100	0,366	●	●	●		
2	2	1	8	0,7	7	0,750	0,900	0,300	●	●	●		
2	2	1	9	0,7	7	0,750	1,000	0,333	●	●	●		

1) Nominal Voltage acc. SAE AS 13441:1998 method 3001.1 meet the MIL-STD 1344, method 3001, Test acc. IEC 60512 test 4a. Method of calculation, utilization warning and Proposals see page 129

Size 3

Part number key

1	2	3	4	5	6	7	8	9	10	11	12	13	14	15	16	17	18	19
		3				-								-				

Standard Contact Configuration	Size	Positions		Contact Ø mm	Nominal Signal Contact Current Load in A (Derating factor see page 130)	Test Voltage acc. VDE 0627:1986-06 (kVeff)	Test Voltage acc. SAE AS13441:1998 method 3001.1 (kVeff)	Nominal Voltage acc. SAE AS13441:1998 method 3001.1 (kVrms) ¹⁾	Termination			View on termination side	
		Solder	Crimp (tools for assembling see page 106)						Print (PCB Layout see page 87)	Pin part	Socket		
	3	0	4	2,0	22	1,500	1,650	0,550	●	●	●		
	3	0	7	1,6	17	1,000	1,800	0,600	●	●	●		
	3	0	8	1,3	14	1,000	1,650	0,550	●	●	●		
	3	1	0	1,3	14	1,000	1,350	0,450	●	●	●		
	3	1	4	0,9	10	0,875	1,350	0,450	●	●	●		
	3	1	6	0,9	10	0,875	1,350	0,450	●	●	●		
	3	1	8	0,9	10	0,875	1,350	0,450	●	●	●		
	3	2	0	0,7	7	1,000	1,100	0,366	●	●	●		
	3	2	2	0,7	7	0,875	1,100	0,366	●	●	●		
	3	2	6	0,7	7	0,875	1,000	0,333	●	●	●		
	3	3	0	0,7	7	0,750	0,900	0,300	●	●	●		

1) Nominal Voltage acc. SAE AS 13441:1998 method 3001.1 meet the MIL-STD 1344, method 3001, Test acc. IEC 60512 test 4a. Method of calculation, utilization warning and Proposals see page 129

Size 4

Part number key

1	2	3	4	5	6	7	8	9	10	11	12	13	14	15	16	17	18	19
		4				-									-			

Size	Positions		Contact Ø mm	Nominal Signal Contact Current Load in A (Derating Factor see page 130)	Test Voltage acc. VDE 0627:1986-06 (kVeff)	Test Voltage acc. SAE AS13441:1998 method 3001.1 (kVeff)	Nominal Voltage acc. SAE AS13441:1998 method 3001.1 (kVrms) ¹⁾	Termination			View on termination side	
								Solder	Crimp (tools for assembling see page 106)	Print (PCB Layout see page 87)	Pin part	Socket
4	0	7	2,0	22	1,500	1,650	0,550	●	●	●		
4	4	0	0,7	7	0,875	1,000	0,333	●	●	●		

Size 5

Part number key

1	2	3	4	5	6	7	8	9	10	11	12	13	14	15	16	17	18	19
		5				-									-			

Size	Positions		Contact Ø mm	Nominal Signal Contact Current Load in A (Derating Factor see page 130)	Test Voltage acc. VDE 0627:1986-06 (kVeff)	Test Voltage acc. SAE AS13441:1998 method 3001.1 (kVeff)	Nominal Voltage acc. SAE AS13441:1998 method 3001.1 (kVrms) ¹⁾	Termination			View on termination side	
								Solder	Crimp (tools for assembling see page 106)	Print (PCB Layout and pin length on request)	Pin part	Socket
5	2	5	20 x 0,9 4 x 3,0 1 x 75 Ω Koax					●	●	●		

1) Nominal Voltage acc. SAE AS 13441:1998 method 3001.1 meet the MIL-STD 1344, method 3001, Test acc. IEC 60512 test 4a.
Method of calculation, utilization warning and Proposals see page 129

Size 6

Part number key

1	2	3	4	5	6	7	8	9	10	11	12	13	14	15	16	17	18	19
		6				-								-				

Standard Contact Configuration	BauSize	Positions	Positions	Contact Ø mm	Nominal Signal Contact Current Load in A (Derating Factor see page 122)	Test Voltage acc. VDE 0627:1986-06 (kVeff)	Test Voltage acc. SAE AS13441:1998 method 3001.1 (kVeff)	Nominal Voltage acc. SAE AS13441:1998 method 3001.1 (kVrms) ¹⁾	Termination			View on termination side	
									Solder	Crimp (Tools for assembling see page 100)	Print (PCB Layout and pin length on request)	Pin part	Socket
6		0	2	2 x 4,0	Special insert: Electrical Datas on Request			●					
6		0	5	5 x 75 Ω Koax	Special insert: Electrical Datas on Request			●					
6		2	2	14 x 0,9 3 x 1,6 3 x 2,5 2 x 75 Ω Koax	Special insert: Electrical Datas on Request			●					

Contact Type / Contact Surface - Contact Diameter

Part number key

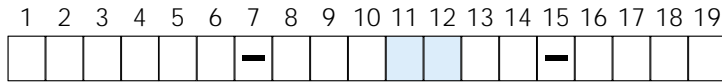

Type	Surface
Socket	L - 0,75 µm Au (min.)
Pin	L - 0,75 µm Au (min.)
Socket	C - 0,75 µm Au (min.)
Pin	C - 0,75 µm Au (min.)
Socket	P - 0,75 µm Au (min.)
Pin	P - 0,75 µm Au (min.)

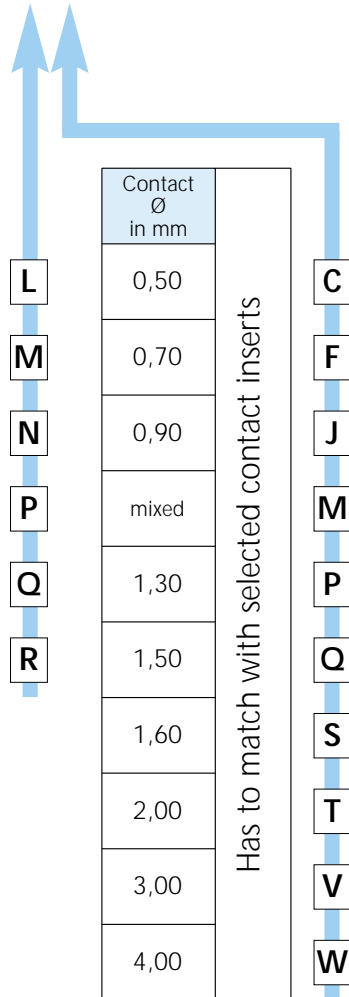

- L = Solder termination
- C = Crimp termination
- P = PCB termination

Contact Termination Cross Sections

Part number key

1	2	3	4	5	6	7	8	9	10	11	12	13	14	15	16	17	18	19
						-								-			0	0

Crimp Contact

Contact Ø	Size	AWG	mm²	
0,7	0	24/26	0,25/0,15	D 0
0,7	0	22	0,38	G 0
0,9	0	24/26	0,25/0,15	D 0
0,9	0	22	0,38	G 0
0,7	1	24/26	0,25/0,15	D 0
0,7	1	22	0,38	G 0
0,9	1	24/26	0,25/0,15	D 0
0,9	1	20/22	0,50/0,38	H 0
1,3	1	18	1,0	L 0
0,7	2	24/26	0,25/0,15	D 0
0,7	2	22	0,38	G 0
0,9	2	24/26	0,25/0,15	D 0
0,9	2	20/22	0,50/0,38	H 0
1,3	2	18	1,0	L 0
0,7	3	24/26	0,25/0,15	D 0
0,7	3	22	0,38	G 0
0,7	3	28/30	0,08/0,05	C 0
0,9	3	24/26	0,25/0,15	D 0
0,9	3	20/22	0,50/0,38	H 0
1,3	3	18	1,0	L 0
1,6	3	16	-	N 0



Tools for crimping and their adjustments see page 106 to 111

Contact Termination Cross Sections

Part number key

1	2	3	4	5	6	7	8	9	10	11	12	13	14	15	16	17	18	19
						-								-			0	0

Solder Contact

Contact Ø	Term. Ø	Term. Cross	
		AWG	mm ²
0,5	0,4	28	0,08
0,7	0,6	26	0,15
0,7	0,85	22	0,38
0,9	0,85	22	0,38
1,3	1,1	20	0,50
1,6	1,4	18	1,00
2,0	1,85	14	1,5
2,0	2,4	-	2,5



C	0
D	0
G	0
G	0
H	0
N	0
Q	0
S	0

PCB Contact

Contact Ø	Term. Ø
0,5	0,5
0,7	0,5
0,9	0,7
1,3	0,7
1,6	0,7
2,0	0,7

0	0
0	0
0	0
0	0
0	0
0	0

For mixed inserts

0	0
---	---

(Please provide details of termination cross section!)



Drilling Patterns for PCB-socket-contacts

	Straight	90° right-angled
Size 00		
2-way		
3-way		
4-way		

Drilling Patterns for PCB-socket-contacts

	Straight	90° right-angled
Size 0		
2-way		
3-way		
4-way		
5-way		
6-way		
7-way		
9-way		

Drilling Patterns for PCB-socket-contacts

	Straight	90° right-angled
Size 1		
2-way		
3-way		
4-way		
5-way		
6-way		
7-way		
8-way		
10-way		
14-way		

Drilling Patterns for PCB-socket-contacts

	Straight	90° right-angled
Size 2		
3-way		
4-way		
5-way		
6-way		
7-way		
8-way		
10-way		
12-way		
14-way		
16-way		

Drilling Patterns for PCB-socket-contacts

	Straight	90° right-angled
Size 2		
18-way		
19-way		

Drilling Patterns for PCB-socket-contacts

	Straight	90° right-angled
Size 3		
4-way		
7-way		
8-way		
10-way		
12-way		
14-way		
18-way		
20-way		
22-way		
26-way		

Drilling Patterns for PCB-socket-contacts

	Straight	90° right-angled
Size 3		
30-way		

Drilling Patterns for PCB-socket-contacts

	Straight	90° right-angled
Size 4		
40-way		