

Miniature Circular Connectors



- HyperSpring® spring loaded contacts, self cleaning wiping action
- 7, 13, 19 ways
- Combine robust environmental performance with compact size and light weight
- Easy and fast snap on locking mechanism
- Full line EMI shielding
- IP67 sealing when mated and unmated
- Different hardware coding to avoid mismatching
- Overmolding solutions
- Upgrade commercial high speed Fast Ethernet, USB, IEEE 1394 interconnect to Mil Spec performances
- High-reliability commercial and military interconnect applications: Tactical Computers, Field Radios, Dismounted Soldier, Weapon Interconnect, Battery Chargers, Missiles, Helmet Breakaway System, Commercial Airframe Sensors, Autosport Diagnostics

Technical Characteristics

General		Vibration	MIL-STD-1344 method 2004 condition III
Hyperspring Contact Number	7,13,19	Shock	MIL-STD-1344 method 2004
Receptacle Contact Termination	Solder Cup, Straight PCB	Weight (Plug+Receptacle -with contacts -without cabling)	9 g (7) 14 g (13) 16 g (19)
Plug Contact Termination	Solder Cup	Materials and Plating	
Cable Diameter Range	Max 6 mm (7) Max 7.5 mm (13) Max 8.5 mm (19)	Housing – Material	Aluminium Alloy
AWG Contact	28-24	– Plating	ZnCo conductive RoHS compliant
Connector Mating Cycles	2000	Overmolding (Plug)	Santoprene
Connector Mating Force	Max 3 Kg	Contact – Material	Brass, CuBe
Connector Unmating Force	Max 4 Kg	– Plating	Gold
Electrical and mechanical characteristics		Environmental Characteristics	
EMI Shielding	Yes	Temperature Range	-65°C +80°C
Current Rating	3A@25°C	Salt Spray	MIL-STD-1344 method 1001 test condition A
Test Voltage (dc) Contact	300 V	Humidity	MIL-STD-1344 method 1002 type II
Dielectric Withstanding Voltage (between contact)	400 V	IP Level	67 mated and unmated
Contact Resistance (low level)	< 15 mOhm		
Insulation Resistance	5000 MOhm @ 500V d.c. (MIL-STD-1344 method 3003)		

7 Ways plug connector ref. 23168

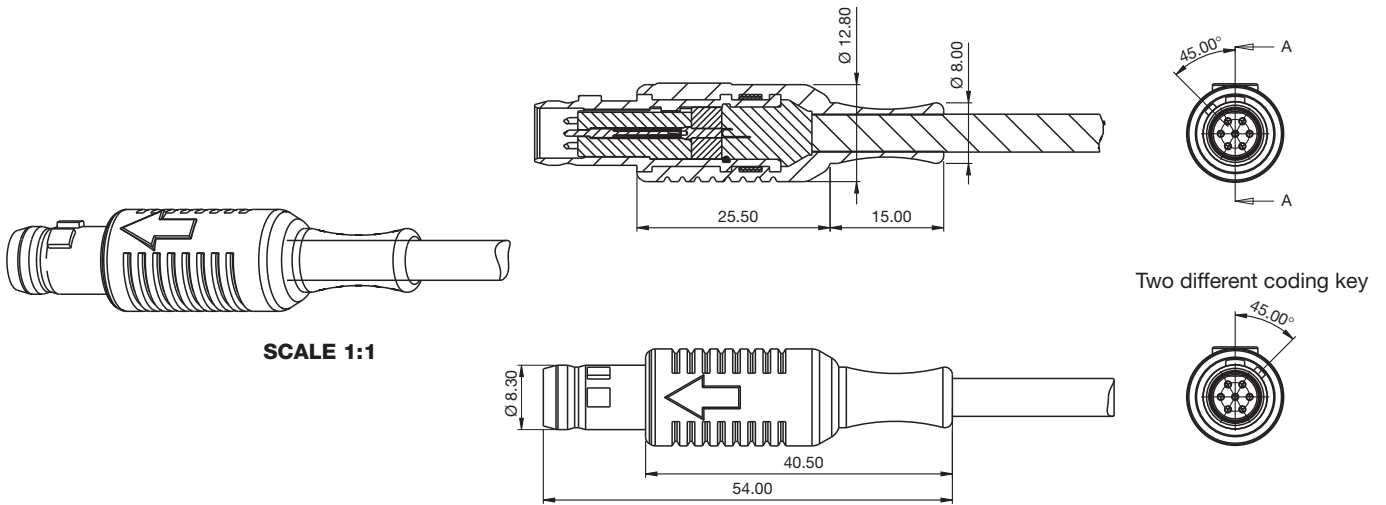

7 Ways receptacle connector straight termination ref. 23167

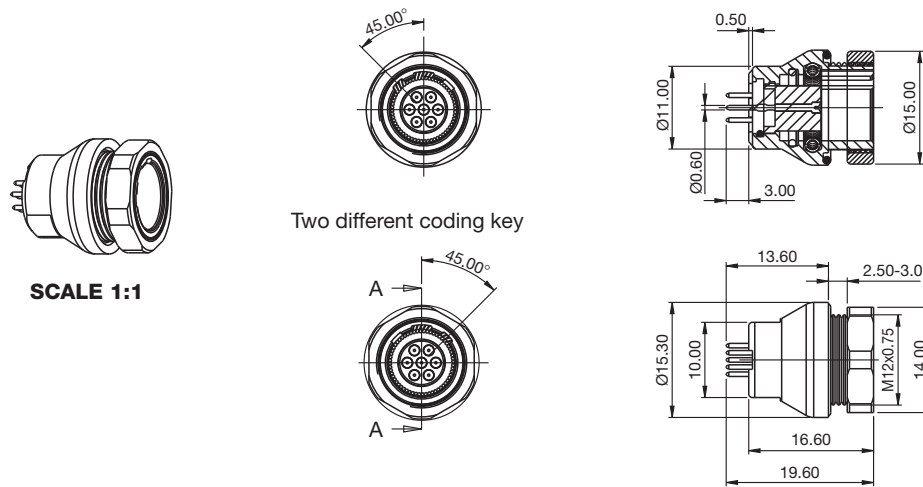

7 Ways extension connector available - contact factory

Panel cut out
Panel thickness max 3 mm

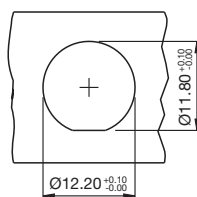

13 Ways plug connector ref. 23178

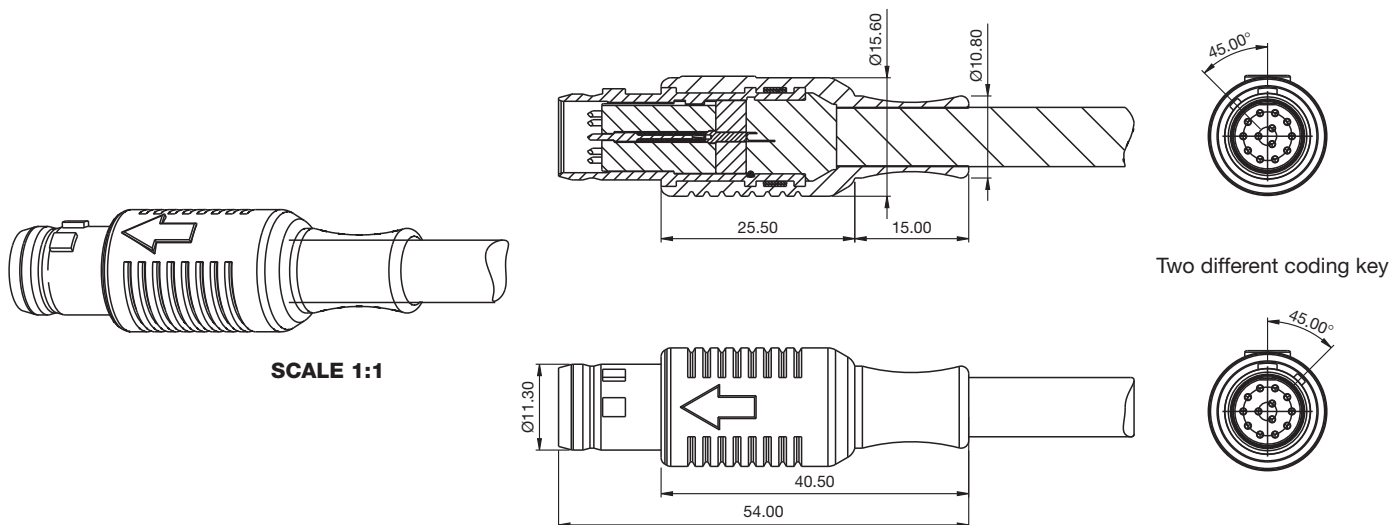

13 Ways receptacle connector straight termination ref. 23177

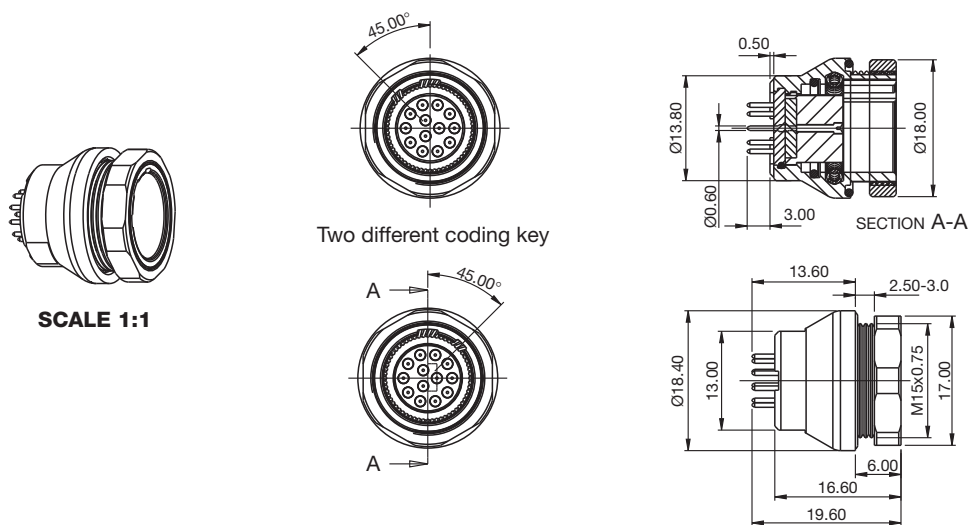

13 Ways extension connector available - contact factory

Panel cut out
Panel thickness max 3 mm

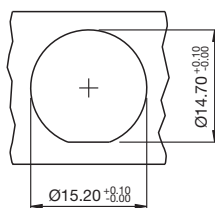

Dimensions are in mm

19 Ways plug connector ref. 23292

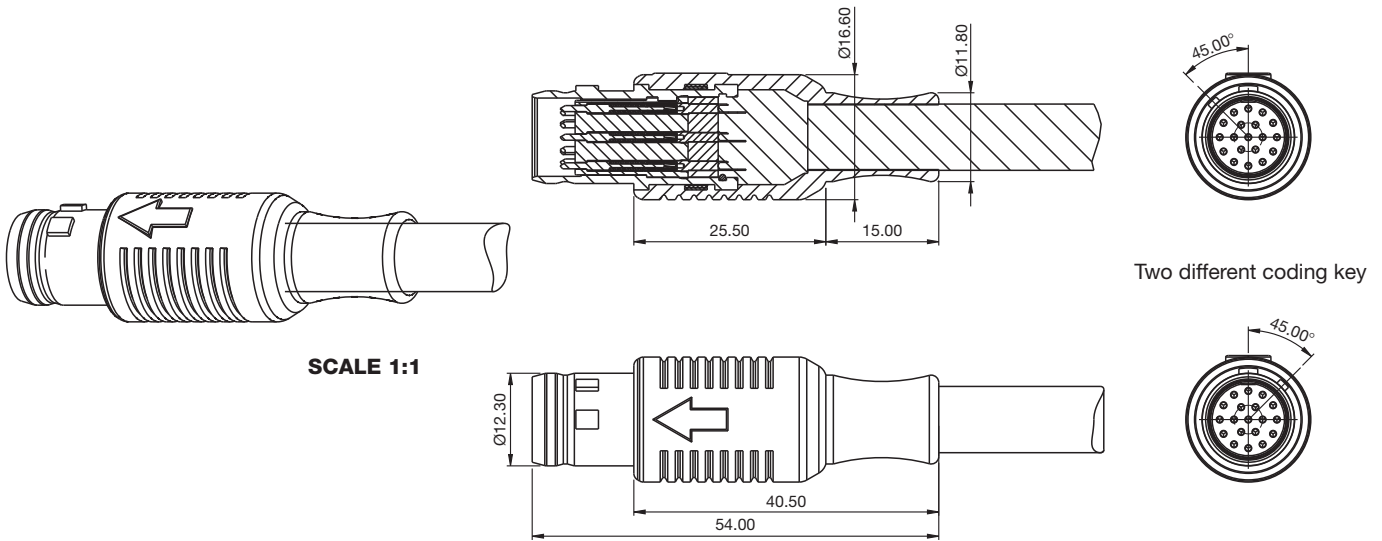

19 Ways receptacle connector straight termination ref. 23294

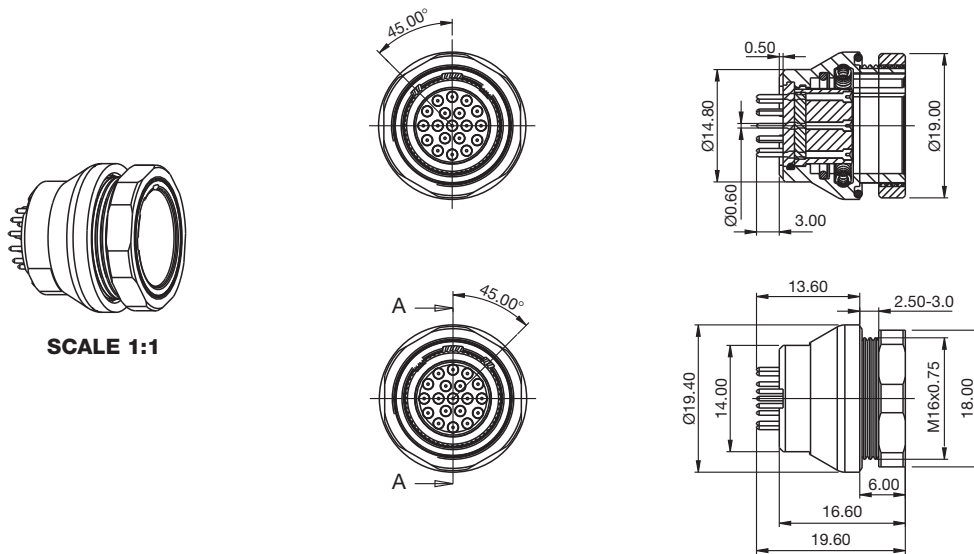

19 Ways extension connector available - contact factory

Panel cut out
Panel thickness max 3 mm

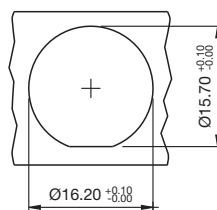

Dimensions are in mm