



# MicroStac<sup>®</sup> 0.8 mm Mezzanine Connector System



# MicroStac® - 0.8 mm Mezzanine Connector System

## Table of Contents

Applications . . . . .	.2
Technical Features . . . . .	.3
Mating Conditions . . . . .	.4
Electrical and Mechanical Characteristics . . . . .	.5
Packaging . . . . .	.7
6 Pin Single Row Version . . . . .	.9
9 Pin Single Row Version . . . . .	.11
12 Pin Single Row Version . . . . .	.13
14 Pin Single Row Version . . . . .	.15
50 Pin Dual Row Version . . . . .	.17
Part Number Index . . . . .	.19
Notes . . . . .	.20

# MicroStac® - 0.8 mm Mezzanine Connector System

## Applications

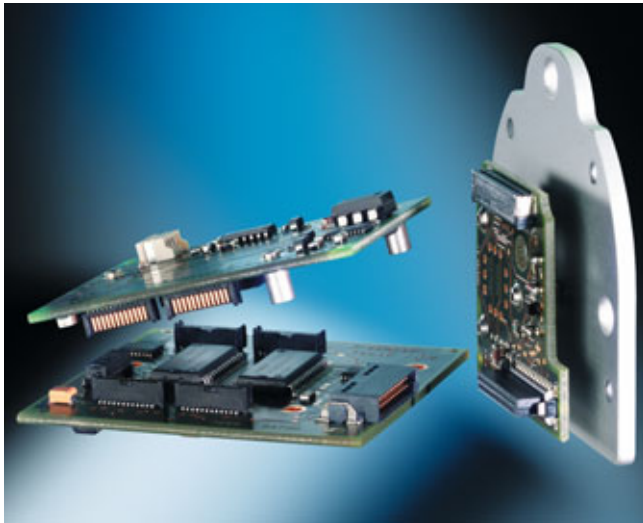

- Sensor engineering: Light barriers, switches
- Medical engineering: Intensive medical equipment, portable diagnostics
- Mobile communication: Mobile phones, PDAs, organizer, memory modules
- Car electronics: Car radios, mobile car phones, mobile car office equipment
- Control engineering: Mini PLCs, fieldbus modules, mini solenoid systems
- Facility management: Signal and indicator devices, alarm systems and bus modules

### Derating Curve

In spite of the small design of the ERNI MicroStac series, they reach a high current rating. The contacts feature large radiant surfaces to derive heat. The derating curve shows the 50pin version without PCB.

For further derating curves related to the according pin count see our webpage.

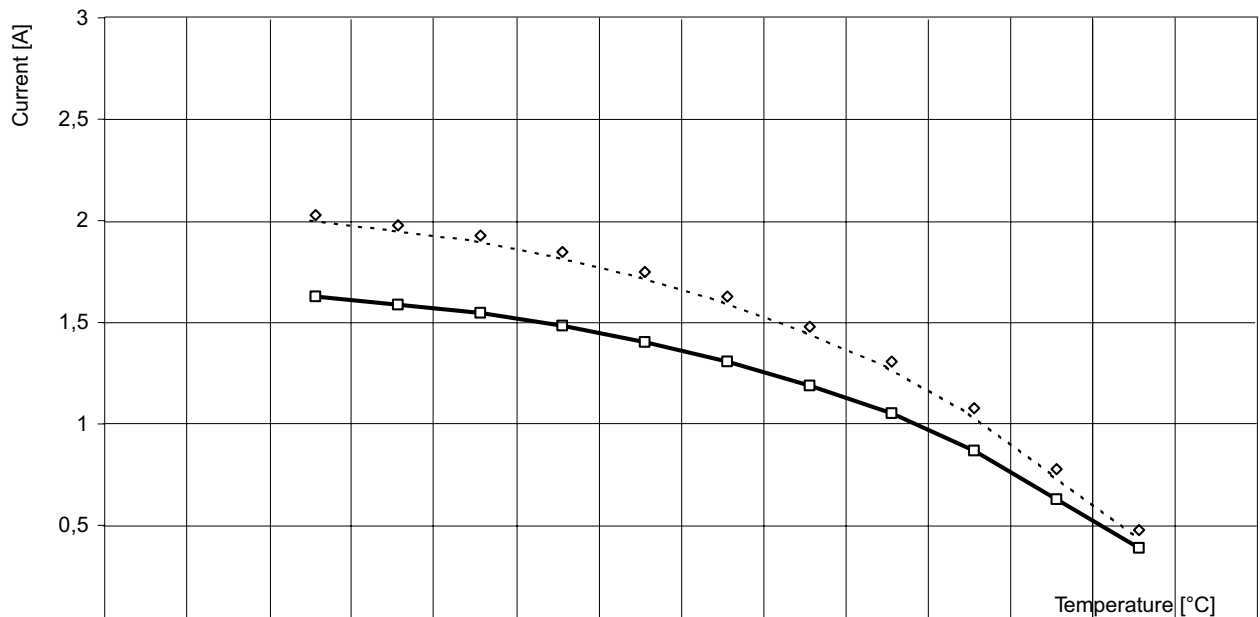

Basecurve[A]			2	1,95	1,9	1,82	1,72	1,6	1,45	1,28	1,05	0,75	0,45	
Derating curve[A]			1,6	1,56	1,52	1,456	1,376	1,28	1,16	1,024	0,84	0,6	0,36	

# MicroStac® - 0.8 mm Mezzanine Connector System

## Technical Features

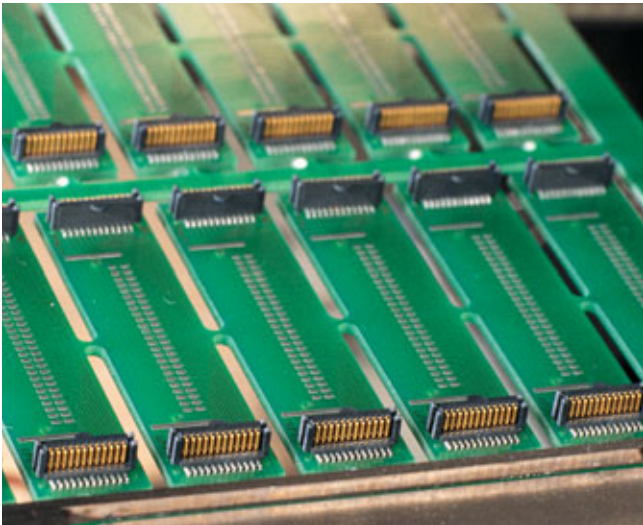

### Controlled SMT Reflow Soldering Process

The heat-resistant thermoplastic insulator and precision coplanar contacts permit a controlled SMT soldering process.



### Safe Packaging and Fully Automated Feed

The antistatic tape and reel packaging not only protects the high-precision contacts and coplanarity of our MicroStac connectors, but also permits placement of connectors by automated pick and place equipment



### Easy Recognition and Secure Handling

The black insulation body ensures easy visual recognition by the automatic pick and place equipment.

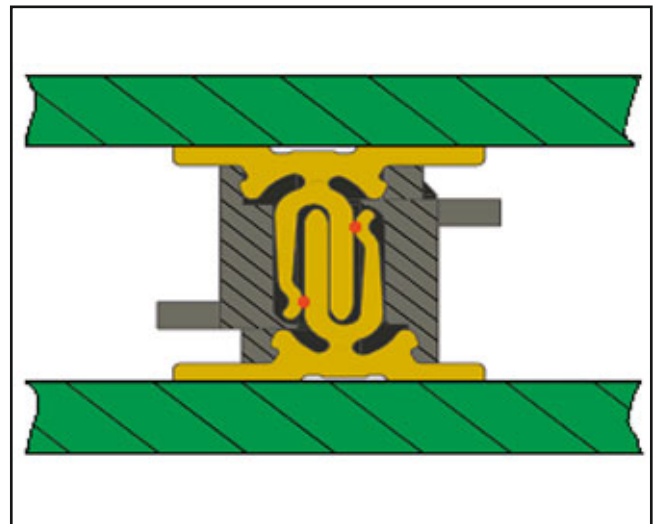

### Contact Design for 5 mm Stacking Height

The MicroStac contacts are based on a patented hermaphroditic contact design with two contact points for compensation of tolerances.

Patent-no.: DE 19 809 881; US 6,379,170

# MicroStac® - 0.8 mm Mezzanine Connector System

## Mating Conditions

**Allowed misalignment tolerances longitudinal:  $\pm 0.7$  mm, transverse:  $\pm 0.5$  mm**

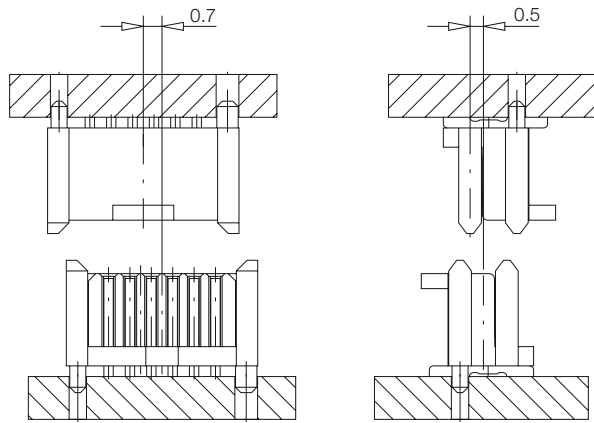

**Allowed angular inclination tolerances longitudinal:  $\pm 4^\circ$ ; transverse:  $\pm 4^\circ$**

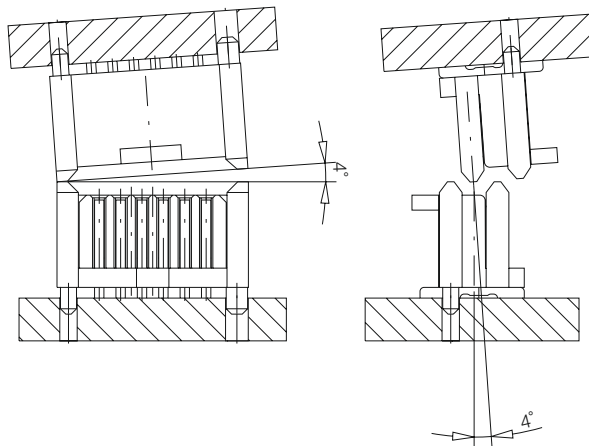

**Wipe length - maximum "Board to Board" distances (5 mm Stacking Height) for secure mating: 1.5 mm**

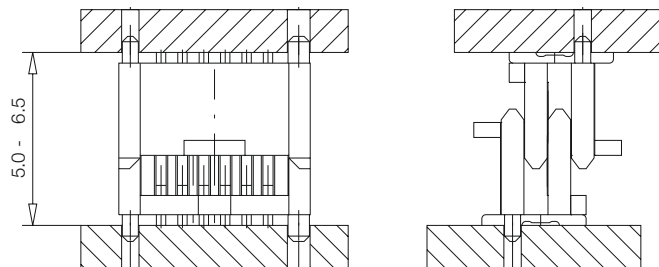

All dimensions in mm

# MicroStac® - 0.8 mm Mezzanine Connector System

## Electrical and Mechanical Characteristics

	Standard	1 Row and 2 Row Versions
Number of Pins		6, 9, 12, 14, 50
<b>Technical data</b>		
Climate Category	DIN EN 60068-1 test b	-55/125/21
Temperature range		-55/125 °C
Current rating per contact		50 pin version: 1.6 A @ 20°C 1.3 A @ 70°C 0.8 A @ 100°C
Air – and creepage distance		0.4 mm
Voltage rating	IEC 60664	The permissible operating voltages depends on the customer application and on the applicable or specified safety requirements. Insulation coordination according to IEC 60664-1 has to be regarded for the complete electrical device. Therefore, the maximum creepage and clearance distances of the mated connectors are specified for consideration as a part of the whole current path. In practice, reductions in creepage or clearance distances may occur due to the conductive pattern of the printed board or the wiring used, and have to be taken into account separately. As a result the creepage and clearance distances for the application may be reduced compared to those of the connector.
Dielectric strength	IEC 60512	contact – contact 500 V <sub>rms</sub>
Contact resistance	IEC 60512 test 2a	< 10 mΩ
Insulation resistance	IEC 60512 test 3a	> 10 <sup>4</sup> MΩ
Vibration, sine	IEC 60512 test 6d	10 – 2000 Hz 20 g
Contact disturbance (while vibration test)	IEC 60512 test 2e	< 1 μs
Shock, halfsine	IEC 60512 test 6c	50 g 11 ms
Contact disturbance (while shock test)	IEC 60512 test 2e	< 1 μs
Mechanical operation (mating cycles)	IEC 60512 test 9a	< 10 mating cycles
Insertion and withdrawal force	IEC 60512 test 13b	3 mm Stacking Height : max. 4 N per contact 5 mm Stacking Height : max. 2 N per contact

## MicroStac® - 0.8 mm Mezzanine Connector System

### Electrical and Mechanical Characteristics

	Standard	1 Row and 2 Row versions
Number of Pins		6, 9, 12, 14, 50
<b>Process-conditions</b>		
Solder temperature max.	IEC 68-2-20	
Hand soldering temperature max.		3.5 s at 350 °C
Dip soldering temperature max.		10 s at 260 °C
Reflow soldering temperature max.	JEDEC J-STD-020C	20 - 40 s at 260 °C
Coplanarity		< 0.1 mm
<b>Housing materials</b>		
Plastic material		PA 46
CTI value	IEC 60112	CTI 225
UL flame rating		UL 94 V-0
UL file		E 47960
<b>Contact materials</b>		
Base material		Cu alloy
Mating area		0.1 µm Au over 1-2 µm Ni
Termination area		4-6 µm Sn over 1-2 µm Ni
<b>Environment compatibility</b>		
Recycling	no flame-retardent additives, no toxic additives allows easy recycling	

# MicroStac® - 0.8 mm Mezzanine Connector System

## Packaging

### 6 Pin Version

Verpackt in Gurtverpackung  
Verpackungseinheit: 1700 Stück

*Tape on Reel Packaging*  
*Packaging unit: 1700 pcs*

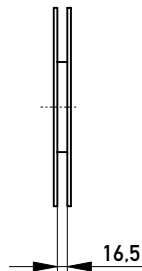
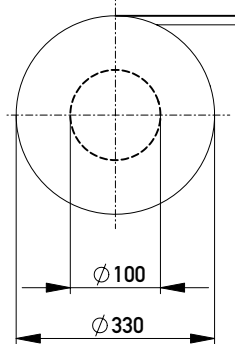

Abspulrichtung - Reel off Direction

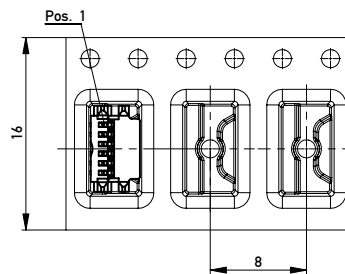

### 9 Pin Version

Verpackt in Gurtverpackung  
Verpackungseinheit: 1750 Stück

*Tape on Reel Packaging*  
*Packaging unit: 1750 pcs*

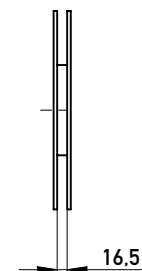
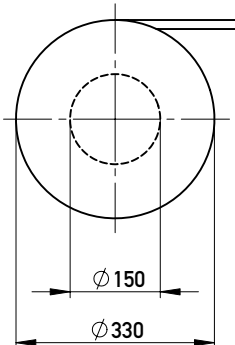

Abspulrichtung - Reel off Direction

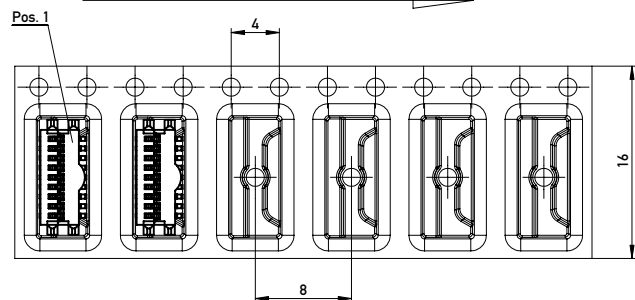

### 12 Pin Version

Verpackt in Gurtverpackung  
Verpackungseinheit: 1300 Stück

*Tape on Reel Packaging*  
*Packaging unit: 1300 pcs*

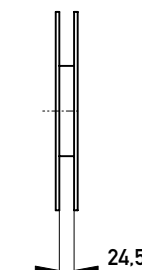
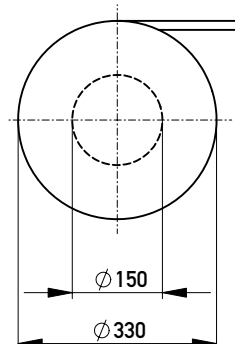

Abspulrichtung - Reel off Direction

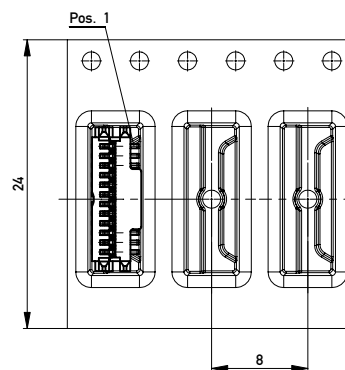

All dimensions in mm

# MicroStac® - 0.8 mm Mezzanine Connector System

## Packaging

### 14 pin Version

Verpackt in Gurtverpackung  
Verpackungseinheit: 1300 Stück

*Tape on Reel Packaging*  
*Packaging unit: 1300 pcs*

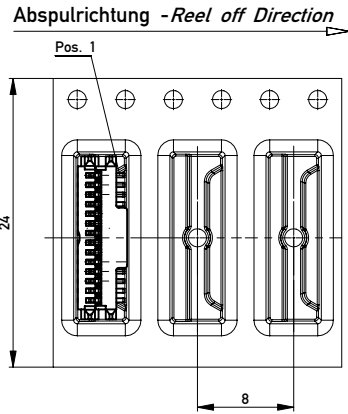
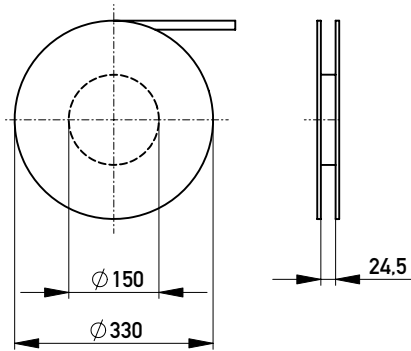

### 50 Pin Version

Verpackt in Gurtverpackung  
Verpackungseinheit: 800 Stück

*Tape on Reel Packaging*  
*Packaging unit: 800 pcs*

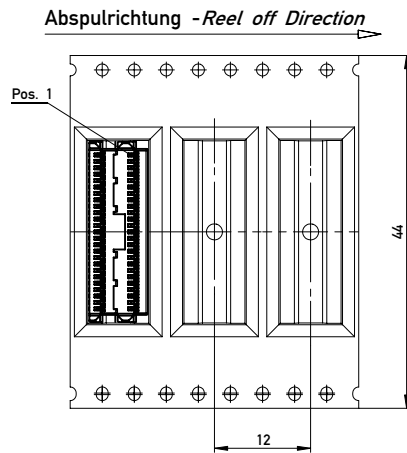
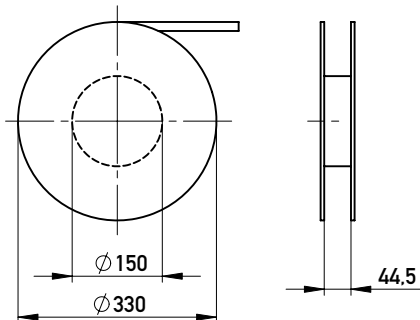

All dimensions in mm

# MicroStac® - 0.8 mm Mezzanine Connector System

## 6 Pin Single Row Version



- Pitch 0.8 mm
  - SMT process compatible
  - Hermaphroditic contact design, two contact points
  - One part number for interconnection saving admin and logistic costs
  - Integrated pick and place pad and very low weight for high speed assembly
  - Positioning pegs
  - Secure standing while solder process, large solder pads
  - Black insulation body and silver terminals for optical vision system (contrast measuring method)
  - Polarization and pre-alignment while mating
- Component weight 6 Pin: 0.14 g
  - Large wipe length 1.5 mm
  - Mated stacking height 5 mm

### Dimensional Drawing

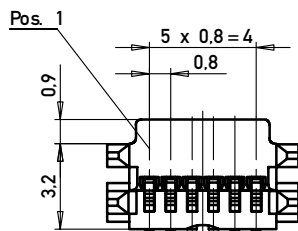
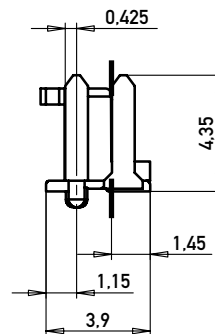
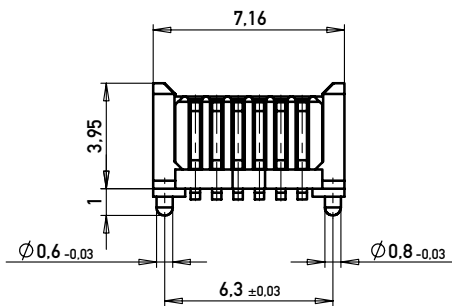

Koplanarität der Anschlüsse  $\leq 0,1\text{mm}$   
*Coplanarity area of termination  $\leq 0,1\text{mm}$*

### Leiterplatten-Layout Vorschlag PCB-Layout Proposal

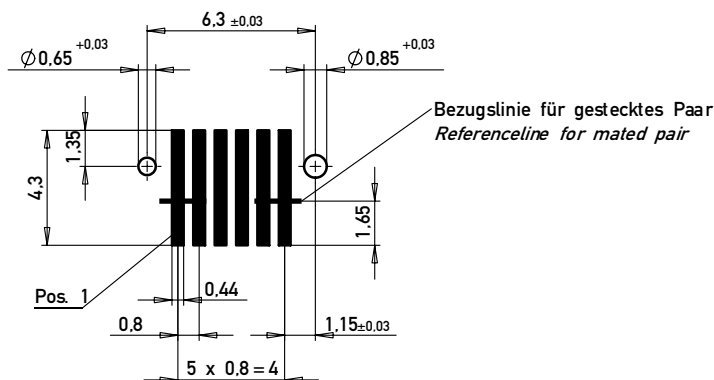

All dimensions in mm

# MicroStac® - 0.8 mm Mezzanine Connector System

## 6 Pin Single Row Version

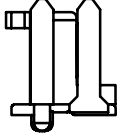
Configuration	Number of Pins	Termination	Mated Stacking Height	Part Number
	6	SMT	5 mm	<b>114711</b>
Single row with peg, tape and reel, 1700 pcs/reel				

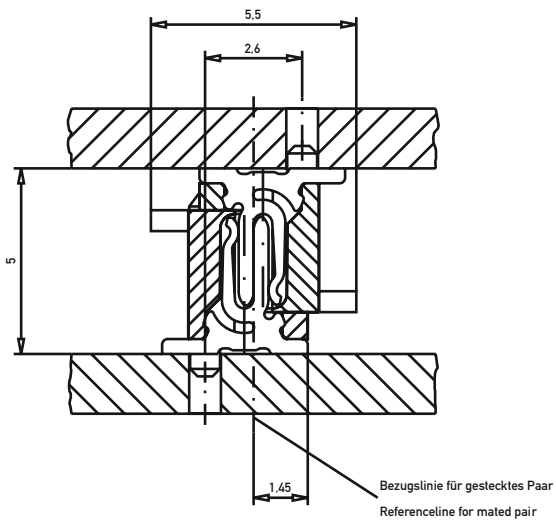

All dimensions in mm

# MicroStac® - 0.8 mm Mezzanine Connector System

## 9 Pin Single Row Version



- Pitch 0.8 mm
  - SMT process compatible
  - Hermaphroditic contact design, two contact points
  - One part number for interconnection saving admin and logistic costs
  - Integrated pick and place pad and very low weight for high speed assembly
  - Positioning pegs
  - Secure standing while solder process, large solder pads
  - Black insulation body and silver terminals for optical vision system (contrast measuring method)
  - Polarization and pre-alignment while mating
- 
- Component weight 9 Pin: 0.12 g
  - Contacts with snap-in function, no wipe length
  - Mated stacking height 3 mm

### Dimensional Drawing

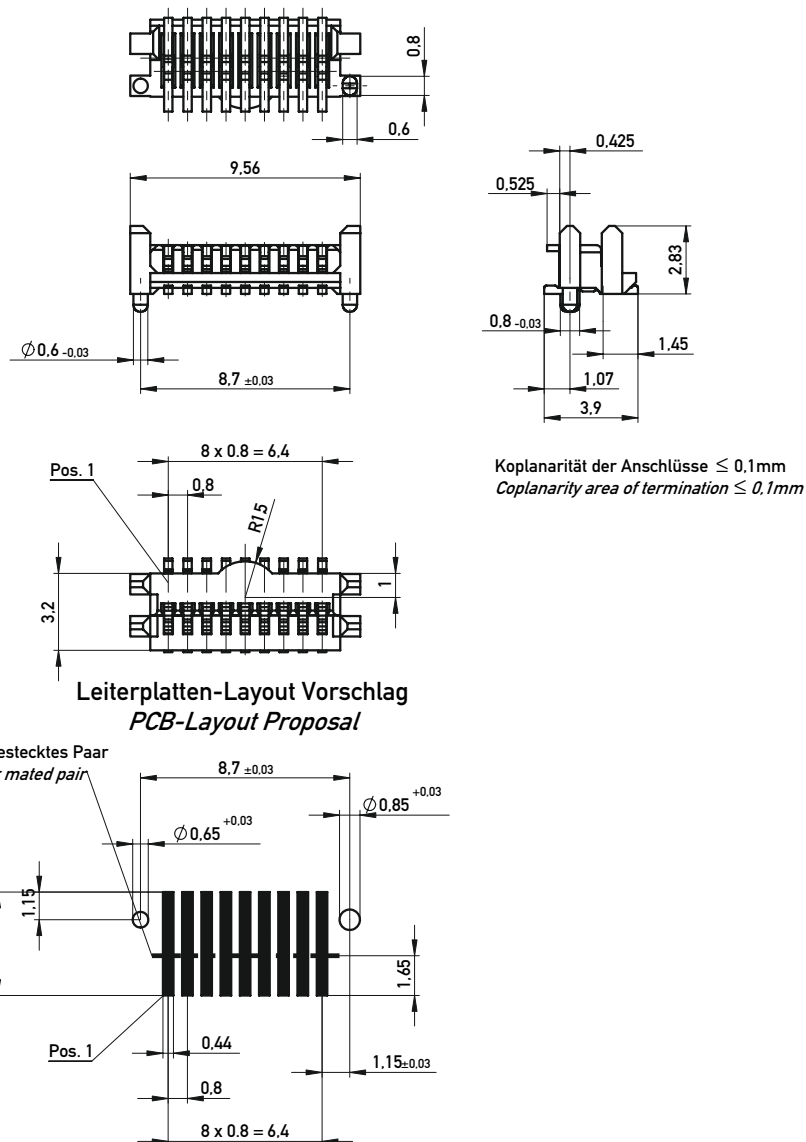

All dimensions in mm

# MicroStac® - 0.8 mm Mezzanine Connector System

## 9 Pin Single Row Version

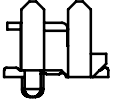
Configuration	Number of Pins	Termination	Mated Stacking Height	Part Number
	9	SMT	3 mm	<b>224920</b>
Single row with peg, tape and reel, 1750 pcs/reel				

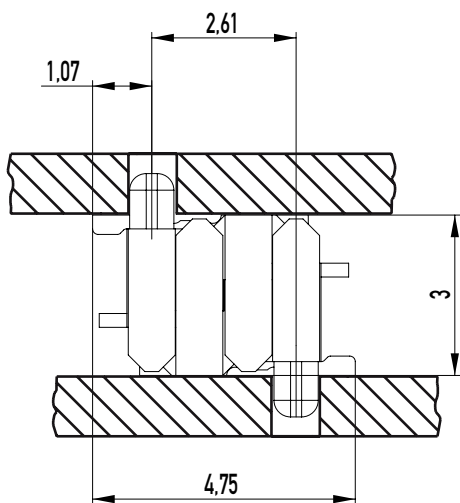

All dimensions in mm

# MicroStac® - 0.8 mm Mezzanine Connector System

## 12 Pin Single Row Version



- Pitch 0.8 mm
  - SMT process compatible
  - Hermaphroditic contact design, two contact points
  - One part number for interconnection saving admin and logistic costs
  - Integrated pick and place pad and very low weight for high speed assembly
  - Positioning pegs
  - Secure standing while solder process, large solder pads
  - Black insulation body and silver terminals for optical vision system (contrast measuring method)
  - Polarization and pre-alignment while mating
- 
- Component weight 12 Pin: 0.26 g
  - Large wipe length 1.5 mm
  - Mated stacking height 5 mm

### Dimensional Drawing

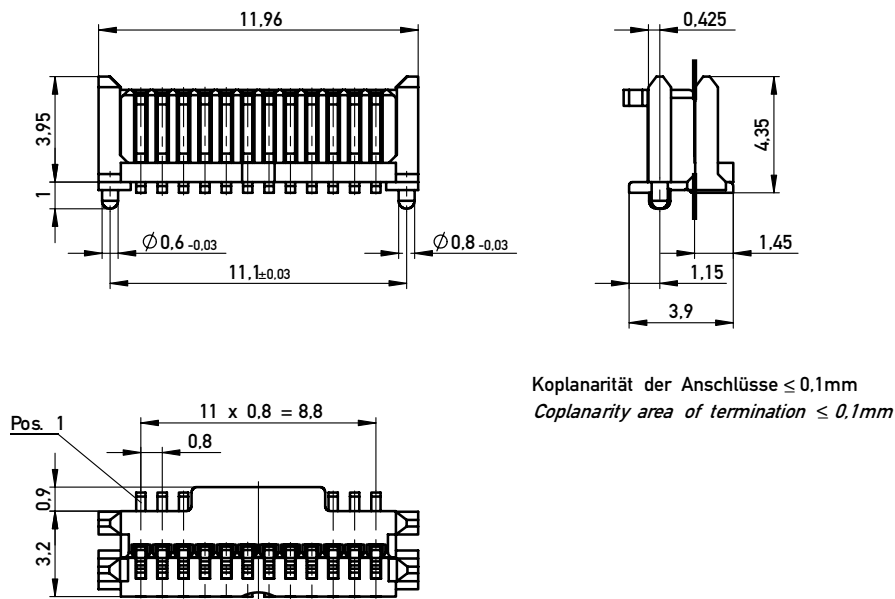

### Leiterplatten-Layout Vorschlag *PCB-Layout Proposal*

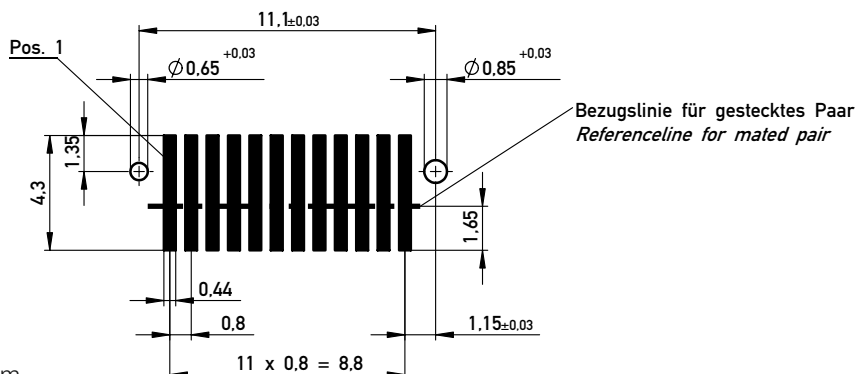

All dimensions in mm

# MicroStac® - 0.8 mm Mezzanine Connector System

## 12 Pin Single Row Version

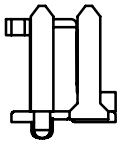
Configuration	Number of Pins	Termination	Mated Stacking Height	Part Number
	12	SMT	5 mm	<b>114712</b>
Single row with peg, tape and reel, 1300 pcs/reel				

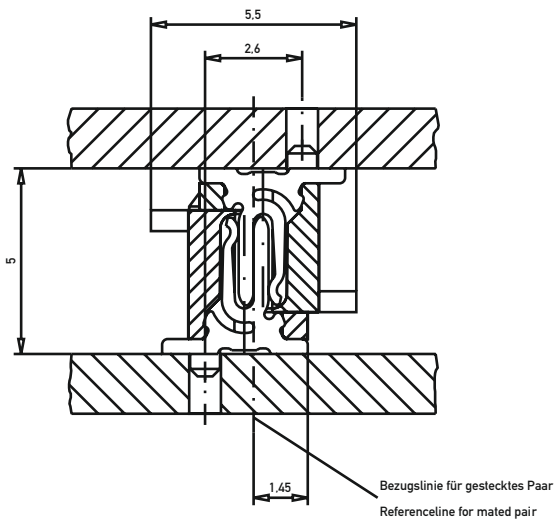

All dimensions in mm

# MicroStac® - 0.8 mm Mezzanine Connector System

## 14 Pin Single Row Version



- Pitch 0.8 mm
  - SMT process compatible
  - Hermaphroditic contact design, two contact points
  - One part number for interconnection saving admin and logistic costs
  - Integrated pick and place pad and very low weight for high speed assembly
  - Positioning pegs
  - Secure standing while solder process, large solder pads
  - Black insulation body and silver terminals for optical vision system (contrast measuring method)
  - Polarization and pre-alignment while mating
- Component weight 14 Pin: 0.30 g
  - Large wipe length 1.5 mm
  - Mated stacking height 5 mm

### Dimensional Drawing

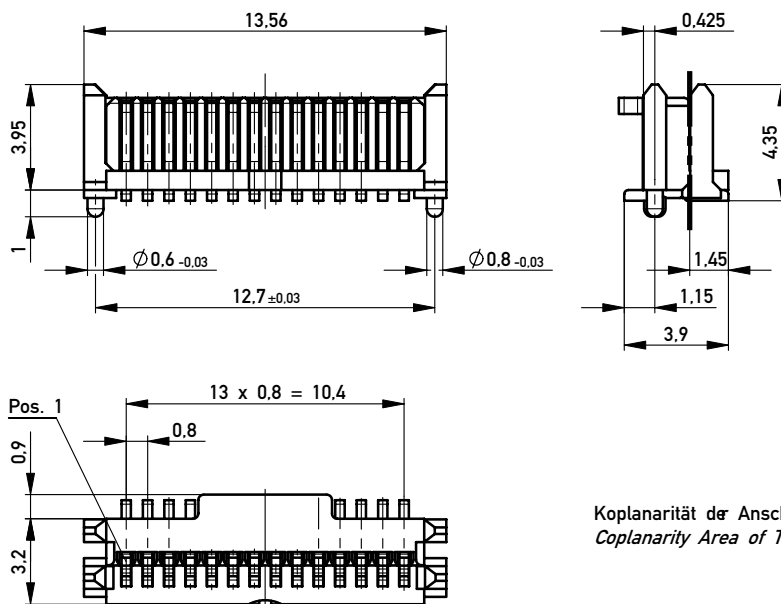

Koplanarität der Anschlüsse 0.1 mm  
Coplanarity Area of Termination 0.1 mm

### Leiterplatten-Layout Vorschlag PCB-Layout Proposal

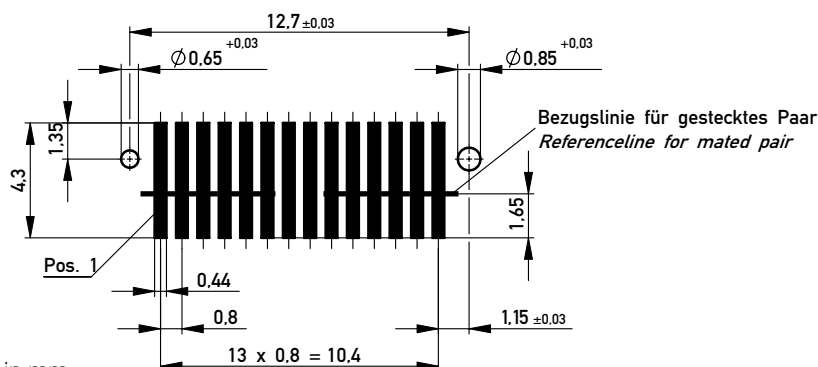

All dimensions in mm

# MicroStac® - 0.8 mm Mezzanine Connector System

## 14 Pin Single Row Version

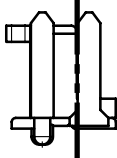
Configuration	Number of Pins	Termination	Mated Stacking Height	Part Number
	14	SMT	5 mm	<b>284257</b>
Single row with peg, tape and reel, 1300 pcs/reel				

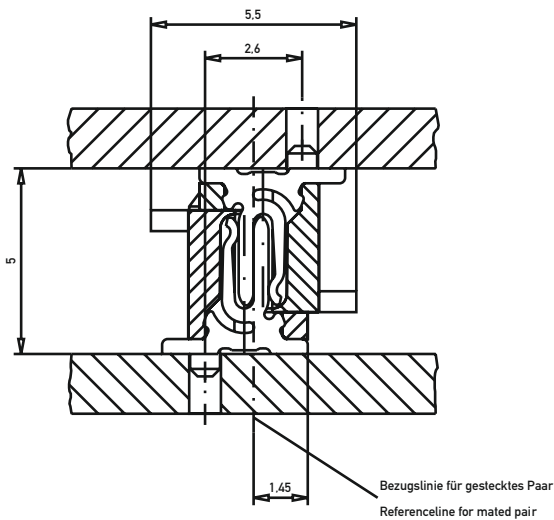

All dimensions in mm

# MicroStac® - 0.8 mm Mezzanine Connector System

## 50 Pin Dual Row Version

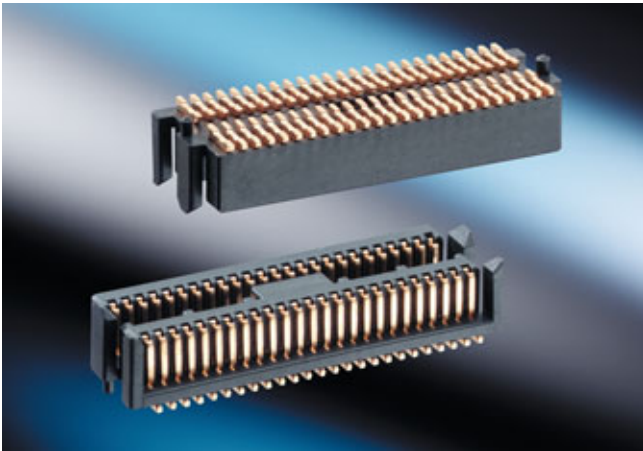

- Pitch 0.8 mm
  - SMT process compatible
  - Hermaphroditic contact design, two contact points
  - One part number for interconnection saving admin and logistic costs
  - Integrated pick and place pad and very low weight for high speed assembly
  - Positioning pegs
  - Secure standing while solder process, large solder pads
  - Black insulation body and silver terminals for optical vision system (contrast measuring method)
  - Polarization and pre-alignment while mating
- Component weight 50 Pin: 0.96 g
  - Large wipe length 1.5 mm
  - Mated stacking height 5 mm

### Dimensional Drawing

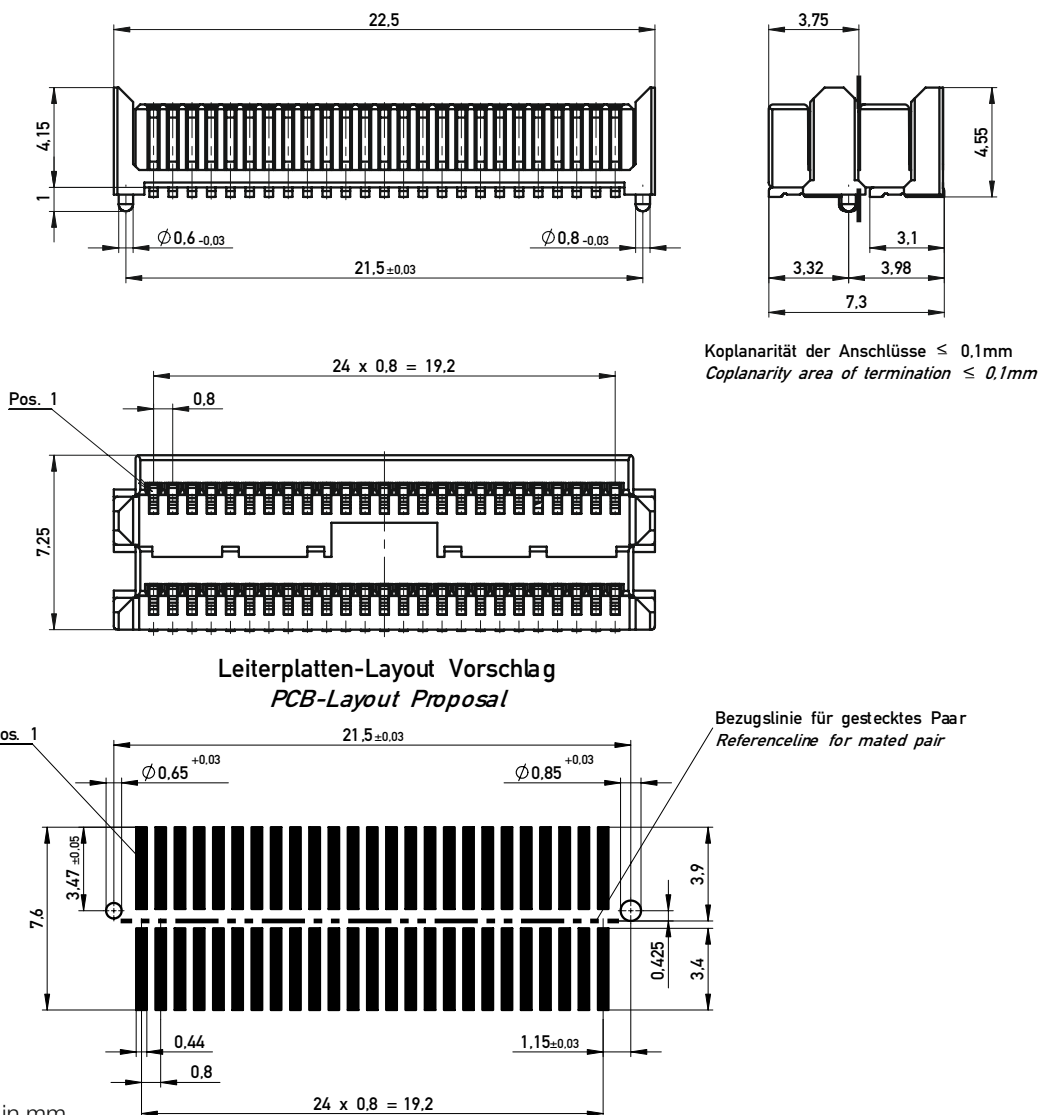

All dimensions in mm

# MicroStac® - 0.8 mm Mezzanine Connector System

## 50 Pin Dual Row Version

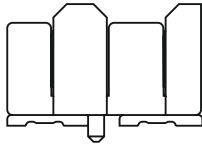
Configuration	Number of Pins	Termination	Mated Stacking Height	Part Number
	50	SMT	5 mm	<b>114713</b>
Dual row with peg, tape and reel, 800 pcs/reel				

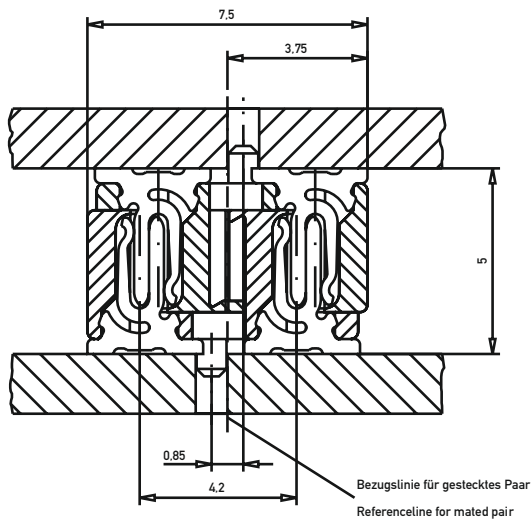
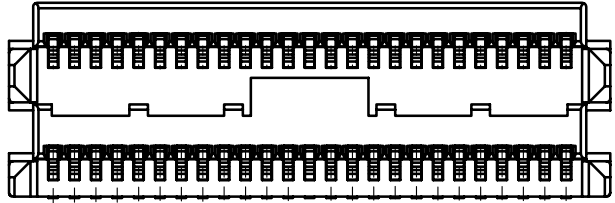

All dimensions in mm

# MicroStac® - 0.8 mm Mezzanine Connector System

## Part Number Index

<b>Part Number</b>	<b>Page</b>
114711.....	10
114712.....	14
114713.....	18
224920.....	12
284257.....	16





Member



VMEbus INTERNATIONAL TRADE ASSOCIATION





**ERNI Electronics GmbH**  
Seestrasse 9  
73099 Adelberg, Germany  
Tel +49 7166 50-0  
Fax +49 7166 50-282  
info@erni.de

Europe South America Africa Japan

**ERNI Electronics, Inc.**  
3005 E. Boundary Terrace  
Midlothian, VA 23112  
Tel +1 804 228-4100  
Fax +1 804 228-4099  
info.usa@erni.com

North America Canada Mexico

**ERNI Asia Holding Pte Ltd.**  
Blk 4008 Ang Mo Kio Avenue 10  
#04-01/02 Techplace I  
Singapore 569625  
Tel +65 6 555 5885  
Fax +65 6 555 5995  
info@erni-asia.com

Asia

[www.erni.com](http://www.erni.com)

© ERNI Electronics GmbH 2008 • Printed in Germany. A policy of continuous improvement is followed and the right to alter any published data without notice is reserved.  
ERNI®, MicroStac®, MicroSpeed®, MiniBridge®, MaxiBridge®, ERmet®, ERmet ZD®, ERbic® and ERNIPRESS® are trademarks (registered or applied for in various countries) of ERNI Electronics GmbH.